



**YOUR
SOLUTIONS**

C O R R O S I V E A P P L I C A T I O N S

User manual

Installation

Operation

Maintenance

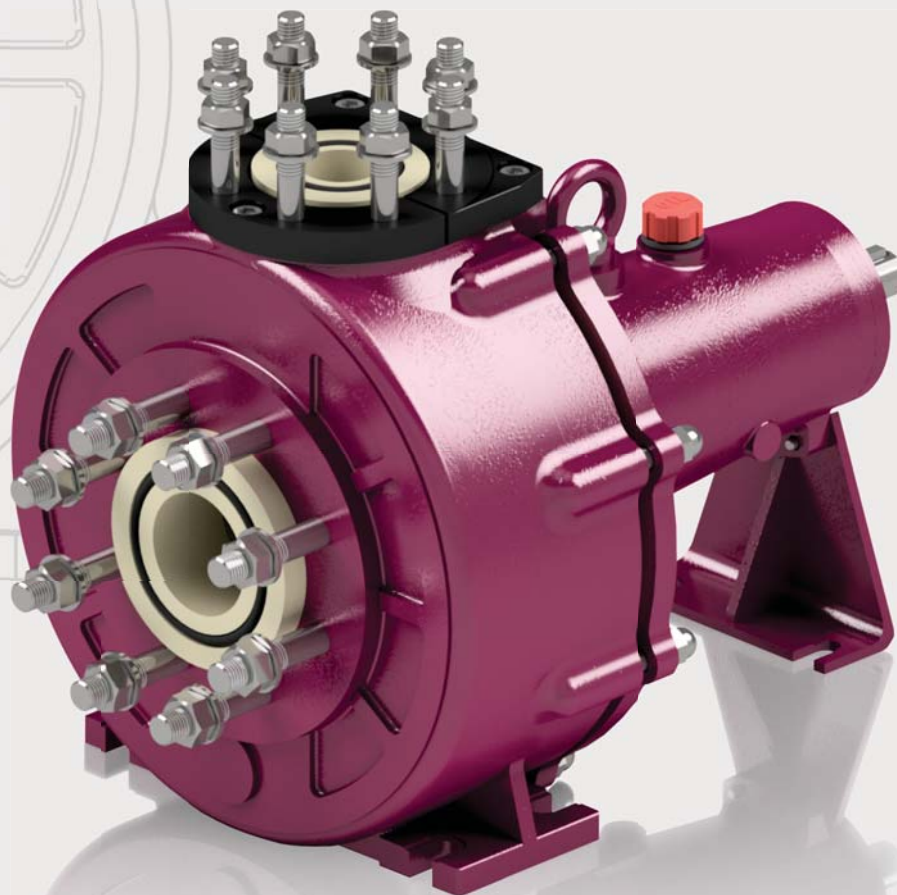

User manual in the original or in different languages should be requested to the manufacturer.

ISO 9001:2015
Certified company



2006/42/EC
Machinery Directive



HDG-002ENX
Translation of the
original instructions

Horizontal centrifugal pumps according to DIN EN 22858 ISO 2858
with mechanical seal

CGD / CGD-E

Index

1.0 GENERAL 3

1.1 EC CONFORMITY DECLARATION	3
1.2 GENERAL INFORMATION	3
1.3 DISCLAIMER AND RIGHTS.	3
1.4 DESCRIPTION OF CGD AND CGD-E RANGES	3
1.5 PUMP CODE	3
1.6 SERIAL NUMBER	3
1.7 MARKING.	3
1.8 CERTIFICATIONS	3
1.9 DOCUMENTATION	4
1.10 WARRANTY	4
1.11 SAFETY	4

2.0 PUMP DESCRIPTION 5

2.1 MAIN PARTS	5
2.2 MAXIMUM OPERATING SPEEDS	6
2.3 MAXIMUM PRESSURES	6
2.4 MINIMUM OPERATING FLOW RATES.	6

3.0 TRANSPORT AND STORAGE 6

3.1 PACKING	6
3.2 TRANSPORT, HANDLING AND HOISTING	6
3.3 INSPECTION	8
3.4 STORAGE	8

4.0 INSTALLATION 9

4.1 LOCATION OF THE PUMP	9
4.2 SUPPORT BASEPLATE AND FOUNDATIONS	9
4.3 ALIGNMENT OF THE PUMP UNIT	9
4.4 PIPING	10
4.5 SUCTION PIPING	11
4.6 DISCHARGE PIPING	11
4.7 FILLING PIPING	11
4.8 DRAINAGE PIPING	11
4.9 FITTINGS	12
4.10 CONTROL INSTRUMENTS	12
4.11 FINAL CHECK	12
4.12 CONNECTION OF THE ELECTRIC MOTOR	12
4.13 CONNECTION OF THE INTERNAL COMBUSTION ENGINE	13
4.14 EXAMPLES OF INSTALLATION	14

5.0 OPERATION 18

5.1 DIRECTION OF ROTATION	18
5.2 PRELIMINARY PUMP TESTING.	18
5.3 FLUSHING	18
5.4 PRELIMINARY MOTOR TESTING	18
5.5 START-UP	18

5.6 OPERATION	18
5.7 SHUTDOWN	18
5.8 TEMPERATURES.	19
5.9 FLOW RANGE	19
5.10 VIBRATION LEVEL	19
5.11 NOISE LEVEL	19

6.0 MAINTENANCE 20

6.1 PREVENTIVE MAINTENANCE	20
6.2 MAINTENANCE INSTRUCTION.	20
6.3 DAILY INSPECTION AND MAINTENANCE	20
6.4 SIX-MONTHLY INSPECTION AND MAINTENANCE	20
6.5 EXTRAORDINARY MAINTENANCE.	21
6.6 GRADE OF LUBRICATING OIL	21
6.7 CRYSTALLIZATION OF PUMPED LIQUID	21
6.8 DRAINING AND CHANGING THE PUMPED LIQUID	21
6.9 DRY RUN OPERATION	21
6.10 IMPURITIES CONTAINED IN THE PUMPED LIQUID	22
6.11 RECOMMENDED SPARE PARTS.	22
6.12 DISPOSAL	22
6.13 RETURNING OF THE PUMP UNIT	22
6.14 DISASSEMBLY OF THE PUMP UNIT	22
6.15 ASSEMBLY OF THE PUMP UNIT.	25
6.16 PUMP-MOTOR AXIS ALIGNMENT.	30
6.17 CAUSES OF TROUBLE AND TROUBLESHOOTING	31

7.0 COMPONENTS LIST 32

7.1 PUMP CASING	34
7.2 BEARING HOUSING	35
7.3 BASE, DRIVE AND COUPLING	36
7.4 JRS - JRS1 - JTP - JRA - JRG SEALS	37
7.5 JR2S - JR2S1 - JT2P - JR2A - JR2G SEALS	38
7.6 B6EDF - B6EDFC - B6E - B6EC - B6EFL - B6EFLC SEALS	39
7.7 B6IDF-B6IDFC-B6IDFH-B6I-B6IC-B6IFL-B6IH-B6IFLH-B6IFLC SEALS 40	
7.8 J5H - J5G - UMS - UMG - UMD SEALS	41

8.0 AUXILIARY COMPONENTS 42

8.1 SYMBOLS LEGEND AND NOTES	42
8.2 FLUSHING SYSTEM FOR SINGLE SEAL: API PLAN 01	42
8.3 FLUSHING SYSTEM FOR SINGLE SEAL: API PLAN 11	42
8.4 FLUSHING SYSTEM FOR SINGLE SEAL: API PLAN 12	42
8.5 FLUSHING SYSTEM FOR SINGLE SEAL: API PLAN 32	43
8.6 FLUSHING SYSTEM FOR DOUBLE SEAL: API PLAN 52	43
8.7 FLUSHING SYSTEM FOR DOUBLE SEAL: API PLAN 53	43
8.8 FLUSHING SYSTEM FOR DOUBLE SEAL: API PLAN 54	44
8.9 CONSTANT LEVEL OILERS	44

9.0 OUTER DIMENSIONS 45

9.1 DIMENSIONS OF BARE SHAFT PUMP	45
9.2 DIMENSIONS OF PUMP UNIT	46

1.0 GENERAL

1.1 EC CONFORMITY DECLARATION

Manufacturer:

Affetti Giuseppe & C. s.n.c.

Via P. Maroncelli, 4

21053 Castellanza (VA) ITALY

The manufacturer declares that the pump unit CGD or CGD-E in the standard designs and supplied with a drive (electric motor or internal combustion engine), baseplate, coupling and coupling guard, complies with the 2006/42/EC Machinery Directive.

Applied harmonized standards:

- EN ISO 12100:2010 General principles for design
- EN ISO 809:2009 Pumps and pump units for liquids

Conformity to the directives and standards listed above is subject to the condition that the pump unit is used in accordance with the conditions of service contractually agreed, this responsibility belong to the end-user.

Any modification to the machine or its use not contractually agreed or not approved in writing by the manufacturer will make null and void this declaration.

The pump unit to which this declaration refers may only be put into operation after they have been installed as specified by the manufacturer and after that the complete system or plant of which these pumps form part complies with the requirements of the Directive 2006/42/EC.

In case of supply of bare shaft pump, the purchaser / user must provide the assembly of the pump unit (pump, drive, baseplate, coupling and coupling guard) according the manufacturer's instructions and verify the compliance to the Directive 2006/42/EC before to put the machinery into operation.

1.2 GENERAL INFORMATION

This manual is written to ensure safe handling of the equipment and its intended use. The equipment must be operated in compliance with these instructions in order to ensure reliability and avoid any risk.

The user / operator must follow the national standards and safety regulations in force, even if they have not been mentioned in this manual.

This information must always be kept close to where the pump is installed or attached to the pump itself.

The user manual must be read and analysed before installing, operating or carrying out any maintenance work on the pump unit.

Failure to comply with the instructions contained in this manual may cause danger to personnel and will void the AFFETTI warranty.

The instructions and information contained in this user manual are only valid for the pump to which the manual is attached. They do not apply to the plant in which the pump unit will be installed.

1.3 DISCLAIMER AND RIGHTS

Information contained in this manual is deemed reliable. The manufacturer shall not be held responsible in the event that, despite their efforts to supply exhaustive and consistent information, the contents of this manual prove to be insufficient. The purchaser/user must check the information contained in this instruction manual and contact the manufacturer for any missing information.

All rights reserved. No part of this manual may be reproduced, stored in any type of system or transmitted in any form whatsoever, nor by any means, without prior authorisation from the manufacturer.

The manufacturer reserves the right to make changes to the structure of the pump without updating previous supplies.

1.4 DESCRIPTION OF CGD AND --E RANGES

The CGD and CGD-E pumps, manufactured in compliance with the ISO 2858 standards, has been developed to be installed horizontally and for pumping corrosive liquids. They are intended to be installed in a suitable plant or system.

The CGD and CGD-E pumps are equipped with the back pull out system that allows the complete rotating elements to be removed for maintenance works without disconnecting the casing from pipework.

Special attention has been dedicated to heavy construction, easy access for maintenance and hydraulic efficiency. Each pump is combined

with a series of motors of different power ratings and satisfies the most varied needs thanks to an optimum ratio between flow and total head in relation to the specific gravity of the pumped liquid, guaranteeing low energy consumption.

1.5 PUMP CODE

The pump code identifies the pump and construction materials.

Code	Description
CGD-E	Name of series
200-315	Size of pump
PVDF	Material of casing and impeller
FPM	Material of O-rings
55 kW	Motor output

TABLE 1.5.1: Identification codes

1.6 SERIAL NUMBER

The serial number is a sequential number used to identify every pump manufactured. It is marked on the pump's tag plate.

1.7 MARKING

Each pump is equipped with a tag plate marked with all of the data required in accordance with the 2006/42 EC Machinery Directive, which also facilitates identification of the pump. For any spare part requests, should be provided the data marked on the pump's tag plate or the serial number.

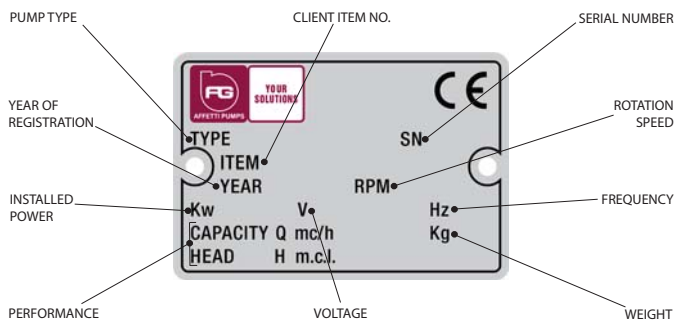

The weight indicated on the tag-plate of the pump refers to the weight of the pump unit (pump, drive, baseplate, coupling and coupling guard). Detailed weights of the single parts are shown in this manual (see table 3.2.3).

NOTE:

In case of supply of bare shaft pump, the weight indicated refers only to the parts provided. For safety reasons, the purchaser / user must provide the permanently fixing of an additional tag-plate indicating the total weight of the pump unit (pump, drive, baseplate, coupling and coupling guard) complies with the Directive 2006/42/EC.

1.8 CERTIFICATIONS

Certifications supplied as standard are:

- 2006/42/EC conformity declaration
- Warranty certificate
- Pump data sheet

Certifications available on request are:

- Certificate of origin
- Certificate of origin for materials
- Material conformity certificate
- Impeller balancing certificate
- Pump shaft balancing certificate
- Hydrostatic test
- Functional test without data recording
- Visual examination and dimensional test
- Vibration measurement (at contractual point)
- A-weighted sound pressure (at contractual point)
- Strip down certificate
- Performance test with report (Q-H-Na-%)
- Performance test with report (Q-H-Na-%-NPSHr)

1.9 DOCUMENTATION

The following documentation is attached to the user manual:

- Cross sectional drawing of the pump
- User manual of the motor
- User manual of the mechanical seal

NOTE: If the above documents were not shipped or sent, they should be required to the manufacturer.

1.10 WARRANTY

The products are guaranteed by our company in so far as they are of our manufacture. Manufacturing or material defects are covered by the warranty unless otherwise agreed, for a period of up to one year from the date of dispatch from our factory (data of invoice) and not more than six months from the date of installation. During this period the manufacturer undertakes to substitute and repair free of charge any appliance found to have been faulty from the start due to manufacturing or material defects.

The warranty provides for the substitution of faulty parts, but only after an investigation has been conducted to prove that any damage to the pump was not caused by external factors, but purely and exclusively by construction faults.

The manufacturer shall not be held liable for damages caused by dry operation, faulty assembly of the pump and/or plant, foreign bodies entering the pump, the use of liquids other than those declared by the purchaser, variations in flow rate, total head or temperature compared to the data indicated at the time of order, water hammer, transport (in the event that the goods travel at the customer's own risk), works carried out by unskilled personnel, etc.

The warranty does not cover direct or indirect compensation for damages caused by our pump to objects or persons or during repair work performed by the purchaser or third parties.

The product will not be covered by the warranty if the customer tampers with it by repairing or even manipulating it without our prior agreement.

The use of any parts or accessories supplied by a third party will render the manufacturer warranty null and void.

The warranty conditions also require that the appliance be forwarded to our factory suitably packed and that after its replacement or repair it be dispatched to the customer with transport and packing charges at their expense.

The manufacturer does not accept liability for our products unless the customer strictly observes all of the contractual clauses.

Work performed under warranty will not affect the warranty period.

Parts subject to wear are not covered by the warranty.

Non-compliance with the indications and instructions given in this manual will void the warranty.

1.11 SAFETY

All personnel involved in operation, installation, inspection and maintenance of the pump must be qualified for the job.

If the personnel are not already qualified for the intended job, the user shall ensure that they receive appropriate training. On request from the operator, the user may ask the manufacturer/supplier to arrange appropriate training which should be appropriately priced and agreed upon according to the formal request.

All original parts and accessories have been designed, tested and incorporated to guarantee the quality of the end product and continuity of the performance characteristics. The use of parts and accessories supplied by third parties may have a negative effect on the performance characteristics and product safety. Damage or failure caused by improper use are not covered by the warranty. Furthermore, any changes made to the equipment or removal of the original components may impair the safety of these products during operation.

This manual contains specific safety symbols, as described here below. Non-observance of the instructions related to the various symbols will result in the creation of a hazardous situation.

 This Hazard symbol indicates safety measures regarding electrical parts. Non-observance of these instructions could pose a serious safety risk for people.

 This warning symbol indicates safety measures. Non-observance of

these instructions could pose a safety risk for people.

 This warning symbol indicates safety measures. Non-observance of these instructions could pose a safety risk for people and the operation of equipment and could result in damage to property.

NOTE: This symbol indicates important instructions that must be followed.

Some important instructions related to safety are given here below:

 Beware of the liquid pumped, avoiding any contact.

 **The pumps of this series are used to transfer dangerous chemicals. The operators should be equipped with appropriate equipment during all procedures of installation, operation and maintenance. Rubber boots, anti-acid overalls and a helmet with a protective visor for the face are essential requirements to allow operators to work without risking their physical safety.**

 In the event of leakages of corrosive or hot liquid immediate actions to avoid the any contact, such as the evacuation of the area, must be taken. The corrosive liquid must be removed by authorized companies in accordance with national laws and regulations.

 Never touch the pump if the liquid pumped exceeds +70°C. Wait until the pump cools down before performing any work.

 When handling a toxic liquid, ventilate the working area.

 Do not drain the pumped liquid out of the casing directly onto the ground. Install a pipe system (including a gate valve) to the drainage hole of the casing (if provided) and drain the pumped liquid into a chemically resistant container or reservoir according to the laws and regulations related to the application, handling and processing of hazardous liquids.

 Do not remove guards and protective devices during the pump operation.

 After maintenance works place and fix again all guards and protective devices. All parts must be assembled before the start-up of the pump.

 Any rotating part should not be freely accessible during the pump operation.

 Handle any sharp components with care.

 Do not put hands or fingers inside the pump's holes, openings or windows.

 Do not stand on the pump or use it as support or step.

 Never perform maintenance work when the pump is connected to the power supply. If a switch has been fitted, make sure it is in the "zero" (off) position. Wait until the pump has stopped completely.

 Do not remove the end caps from the nozzle of the pump until the installation. Place them again when the pump is removed from the system.

 **CAUTION** Never start the pump without liquid inside the casing.

 **CAUTION** The gate valves in the suction pipe must be fully open when the pump is starting or operating.

 **CAUTION** Comply with the limits of flow and use specified in the order confirmation.

 **CAUTION** Prevent the entry of foreign objects into the pump.

 **CAUTION** Never choke the pipes when the pump is in operation.

 **DANGER** Electrical motor and other devices must be installed according to the safety regulations in force.

 **DANGER** If pump is used on variable speed drive, do not exceed the frequency for which the pump was designed.

 **DANGER** Run the at the specified power supply voltage on the tag plate of the motor.

 **DANGER** Install an earth leakage breaker.

 **DANGER** Arrange grounding.

2.0 PUMP DESCRIPTION

2.1 MAIN PARTS

2.1.1 Casing

The casing is equipped with a volute and the suction inlet and delivery outlet are in an axial position, thereby meeting standard plant requirements. It has flanged connections according to ISO standards (according to ANSI standards on request).

In the lowest area of the casing is provided on request a threaded hole to allow the complete drainage of any liquid remaining in the pump.

2.1.2 Impeller

The impeller is the semi-open or closed type; the blades on the rear side reduce the axial thrust caused by the flow of liquid during the working operation. Its size depends on the performance required.

2.1.3 Shaft

The shaft transmits to the impeller the rotary motion generated by the drive. It is connected to the drive by an flexible coupling with spacer and is supported by a cast iron frame with two ball bearings.

2.1.4 Gland

The gland contains the mechanical seal. On request it is provided with a threaded connection on the bottom in order to connect a pipe system to evacuate eventually leakages of liquid from the mechanical seal. For double mechanical seals it is provided with two threaded connections on the sides to inject the auxiliary liquid (see chapter 8).

2.1.5 Bearings

Radial cylindrical ball bearings are used. The bearings are oil lubricated and their temperature must be monitored constantly whilst the equipment is running (see paragraph 5.8.1).

2.1.6 Mechanical seal

The mechanical seal prevents fluid leaks from the pump. Various types and

brands of seals can be used. The selection is made at the time of offer according to the pump's operating conditions and compatibility with the liquid pumped.

 **CAUTION** The mechanical seal must never be run dry.

NOTE: The seal does not require auxiliary lubrication with oil or grease.

NOTE: The working lengths of mechanical seals are indicated on pages 35-39.

2.1.7 Frame

The heavy construction frame consists of a single piece purposely designed to support the pump shaft by two bearings.

The frame size or group depends on the pump model as indicated below:

Pump model	Group (Frame)	Pump model	Group (Frame)
32-160	I	80-250	II
32-200	I	80-315	III
40-160	I	80-400	III
40-200	I	100-200	II
40-250	II	100-250	III
50-160	I	100-315	III
50-200	I	125-250	III
50-250	II	125-315	III
50-315	II	150-250	III
65-160	II	150-315	IV
65-200	II	150-400	IV
65-250	II	200-315	IV
80-200	II	200-400	IV

TABLE 2.1.7.1: Frame sizes or groups.

2.1.8 Baseplate, coupling and coupling guard

As far as the ranges of CGD and CGD-E pumps are concerned, the baseplate is entirely constructed of electro-welded carbon steel and is equipped with a coupling guard of the same material. The coupling is the flexible type with spacer. If supplied bare shaft, the same type of coupling must be used.

 **DANGER** The baseplate is provided (on request) with a drip-pan for pump leakages. The drip-pan has a drain hole that should be connected to a drainage piping with a check valve. Leakages should be conveyed in a chemically resistant reservoir. The leakages level must never exceed the maximum capacity of the drip-pan.

NOTE: If not provided by the manufacturer, the purchaser / user must assembly a coupling guard designed according to ISO 13857:2008.

2.1.9 Drive

The motors installed comply with the IEC standards (NEMA on request), have an IP55 protection rating and are built in insulation class F, unless other special requirements apply.

NOTE: On request the pump can be provided with an internal combustion engine.

NOTE: The user manual of the drive is provided with the goods. It has the same importance of the user manual of the pump and should be read and analysed before all operations.

2.2 MAXIMUM OPERATING SPEEDS

Pump model	Max. RPM
32-160	3500
32-200	3500
40-160	3500
40-200	3500
40-250	3500
50-160	3500
50-200	3500
50-250	3500
50-315	1780
65-160	3500
65-200	3500
65-250	3500
80-200	3500
80-250	3500
80-315	1780
80-400	1780
100-200	3500
100-250	3500
100-315	1780
125-250	1780
125-315	1780
150-250	1780
150-315	1780
150-400	1780
200-315	1780
200-400	1780

TABLE 2.2.1: Maximum operating speeds.

2.3 MAXIMUM PRESSURES

The maximum pressure (including the hydrostatic test) is equal to 1.5 times the maximum working pressure at the duty point (specified on the purchase order). Higher factor or different conditions must be agreed with the manufacturer.

 Apply higher pressures than those agreed could pose a safety risk for people and the operation of equipment and could result in damage to property.

2.4 MINIMUM OPERATING FLOW RATES

The minimum flow value (continuous flow) must be maintained with regard to the pump's best efficiency point (BEP) as indicated in the following table:

Pump model	% BEP	
	3500-2950	1780-1480
32-160	15%	15%
32-200	15%	15%
40-160	15%	15%
40-200	15%	15%
40-250	20%	20%
50-160	15%	15%
50-200	15%	15%
50-250	20%	20%

50-315	N/A	25%
65-160	15%	15%
65-200	20%	20%
65-250	20%	20%
80-200	20%	20%
80-250	30%	25%
80-315	N/A	25%
80-400	N/A	25%
100-200	20%	20%
100-250	30%	25%
100-315	N/A	25%
125-250	N/A	25%
125-315	N/A	25%
150-250	N/A	25%
150-315	N/A	25%
150-400	N/A	25%
200-315	N/A	30%
200-400	N/A	30%

TABLE 2.4.1: Minimum operating flow rates (continuous flow).

NOTE: The maximum flow value must not exceed 125% of the pump's best efficiency point (BEP).

NOTE: If the flow rate required is less than the minimum flow rate, the equipment must be equipped with a by-pass system in order to guarantee the return of excess liquid from the discharge pipe (before the gate valve) to the suction reservoir.

3.0 TRANSPORT AND STORAGE

3.1 PACKING

The packaging structure and materials are chosen according to shape, dimensions and weight of the good to be shipped.

The following procedure should be followed on receipt of the goods:

1. Check that the contents correspond with that specified on the transport document and your order.
2. Check whether the packaging shows any sign of damage that may have occurred during transport.
3. Carefully remove the contents from the packaging.

NOTE: If the pump unit has been damaged during transport, save the packaging and notify the forwarder immediately. Furthermore, contact the manufacturer to check product functionality.

3.2 TRANSPORT, HANDLING AND HOISTING

Great care must be taken with transport as it is a delicate operation and very important for the correct operation of the pump unit.

Loading and unloading of the goods must be performed taking into account the shape, weight and nature of the packaging.

Hoisting should be done without putting any stress on the pump's most fragile parts (plastic parts and connections). The packed pump unit should be set down gently and without knocking it and it must be fixed and supported so that it does not move from its original position and is not exposed to strong vibrations during transport.

Unloading at the customer's premises must be performed with the same precautions taken for loading.

Instructions for transport, handling and hoisting are given below:

- Before handling, check the weight, size and centre of gravity of the component (provided on request) to be handled (see table 3.2.3 and 3.2.4).
- If the pump unit needs to be moved after it has been installed, make sure that the pump has been drained (if drainage hole is provided).
- Always hoist the pump unit from the recommended hoisting points (see illustration 3.2.2).
- Always hoist the pump horizontally, never vertically.
- The ropes or slings must not create an angle greater than 90°.
- The handles provided for hoisting a single component must not be used to hoist the entire unit.
- Never hoist the pump unit using the motor's handles.

Never pass below a hoisted load.

Use oversized lifting gears appropriate for the total weight to be transported.

For loads greater than the manual handling (including spare parts) use a suitable, type-tested hoisting system that is in good condition connected to rings, eyebolts, holes or threaded terminals of the part to lift. Goods must only be handled by suitably trained personnel, according to the relevant regulations in force.

Safety systems and protective equipment such as gloves, helmets and safety shoes must be used to protect personnel during goods handling.

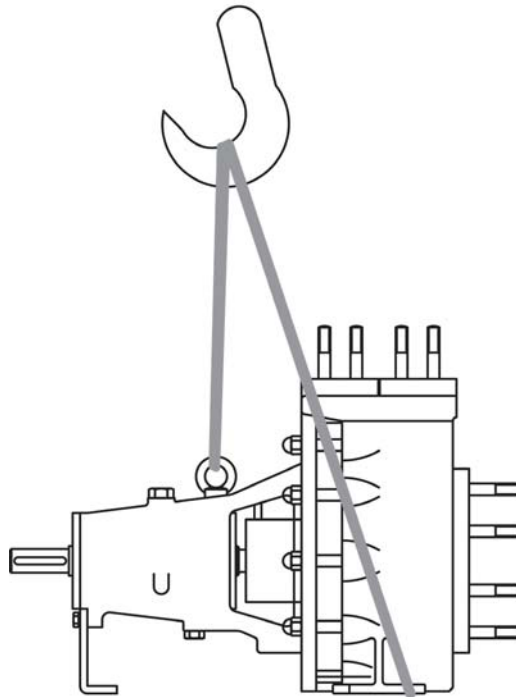

ILLUSTRATION 3.2.1: Handling a bare shaft pump

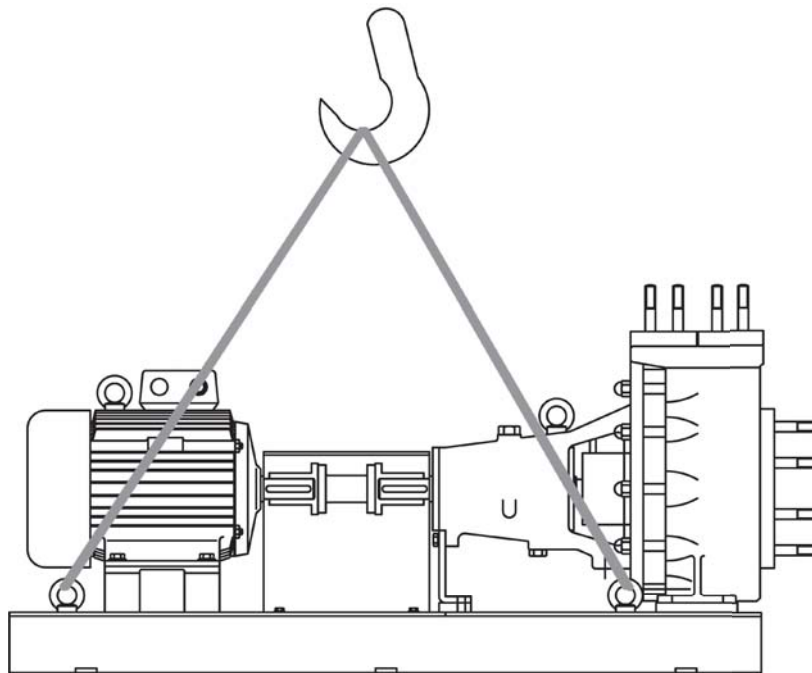

ILLUSTRATION 3.2.2: Hoisting a pump unit with baseplate

Weights of components in Kg			
Model	Motor frame	Pump weight	Coupling and base mass
32-160	80	38	18.5
	160		23
32-200	80	46	18.5
	160		23
40-160	80	45	18.5
	160		23
40-200	80	51	19
	160		23
40-250	80	83	25
	200		31
50-160	80	52	19
	160		23
50-200	90	53	20
	180		28
50-250	90	85	26
	200		55
50-315	100	105	28
	200		37
65-160	80	50	21
	160		26
65-200	90	85	26
	200		32
65-250	100	112	28
	225		40
80-200	100	80	26
	225		34
80-250	112	133	30
	280		51
80-315	132	131	37
	250		53
80-400	160	196	38
	315		45
100-200	100	102	29
	225		34
100-250	132	133	38
	315		43
100-315	132	150	37
	315		41
125-250	132	130	37
	250		41
125-315	160	200	35
	315		55
150-250	132	160	37
	280		43
150-315	160	270	52
	315		61

150-400	180	320	52
	315		61
200-315	180	295	64
	315		69
200-400	180	370	64
	315		74

TABLE 3.2.3: pump, motor, baseplate and coupling masses. The values given are approximate.

Mass in Kg. 2-pole motors 2950 RPM		Mass in Kg. 4-pole motors 1480 RPM	
Kw	Mass	Kw	Mass
0.75	8	0.75	9.5
1.1	9.6	1.1	12.8
1.5	12.9	1.5	15
2.2	15.5	2.2	21
3	22	3	24.8
4	27	4	31
5.5	39.5	5.5	42
7.5	45	7.5	52
9	52	9	58
11	67	11	74
15	78	15	88
18.5	87	18.5	100
22	98	22	122
30	130	30	146
37	148	37	207
45	210	45	230
55	225	55	264
75	335	75	362
90	378	90	427
110	713	110	455
132	713	132	739
160	780	160	812
200	930	200	990

TABLE 3.2.4: motor masses. The values are purely an indication and refer to Marelli motors.

3.3 INSPECTION

A thorough inspection should be conducted on arrival of the goods. The manufacturer is not responsible for damages to the pump components during the transport. In case damages occurred during transport, the responsible forwarding agent should be contacted.

NOTE: For safety reasons some components or accessories may be contained within the main package but packaged separately. Inspect the inside of the case after removing the pump unit.

3.4 STORAGE

Dispatched pump unit is normally expected to be installed within a brief period of time. If a longer period of storage will be necessary, make sure that the place where the pump unit will be stored is dry, clean, far from sources of vibrations, radiations and inflammable or explosive materials and not exposed to the sun or heat sources to prevent any damage occurring before the equipment is installed.



The stored pump unit must be protected against humidity and dirt and should not be accessible to unauthorized personnel.

! The pump stored after use should not contain any liquid or solid particles. The pump should be internally washed and the fluid drained before storage.

Below general instructions that should be followed:

- Store the pump unit indoors in a package. If the pump unit will be stored outdoors, the packaging must be waterproof and prevent the infiltration of humidity.
- Place the stored pump unit horizontally and cover it with a waterproof canvas.
- Place all equipment upon skids or block to prevent contact with ground or surfaces contaminants and support them to prevent distortion or bending.
- Do not place heavy objects on the packaged products.
- Protect the stored pump unit from splashes or corrosive substances.
- Maintain the temperature in the storage area from +5 °C to +35°C. The storage temperature must always be above the freezing point.
- During storage, once a week, rotate the shaft head manually for at least 5 turns in the direction of rotation (via coupling) to prevent the contact faces from seizing up due to friction.
- Do not remove the end plugs on the ports of the pump until ready to install the equipment.
- Clean the pump thoroughly before install it on the plant, eliminating any foreign bodies that could compromise its correct operation.

! The motor should be storage according to the manufacturer's instructions.

NOTE: The storage instructions must be also applied to the auxiliary components and spare parts.

! After a long period of storage should be checked the quantity of oil in the bearing housing (frame) before the installation of the unit according to the paragraph 6.6.

! After a long period of storage elastomeric elements could lose its elastic properties. In this case replace them with new parts.

! The manufacturer provides protections assembled to the terminals of the bare shaft pumps and motors. Bare shaft pump and motor should be always stored or sent back to the manufacturer with protections assembled.

NOTE: On the user request, after a long period of storage or before the installation a manufacturer's representative could be employed to conduct a priced inspection.

NOTE: The manufacturer does not accept any liability for defects due to incorrect storage.

4.0 INSTALLATION

Read this manual carefully before installation. Personnel performing the installation must be aware of all of the information contained herein. Failure to follow these instructions could cause serious damage to the pump unit, which would no longer be covered by the warranty.

4.1 LOCATION OF THE PUMP UNIT

! The follow operations must only be performed by specialized and trained staff.

The pump unit has to be installed in the best possible position to ensure:

- Easy installation of the suction and discharge pipes.
- Easy access for inspection during normal duty or for maintenance work.
- Proximity to the suction tank or reservoir.
- NPSH available 1 meter greater than NPSH required.

NOTE: The ambient temperature should be between +5 and +35 °C and the humidity should not be higher than 85% RH.

NOTE: The place of installation must always be clean, well-ventilated and sufficiently lit (with natural or artificial lighting according to 89/654/EEC).

! The pump unit should not be installed in earthquake or fire risk areas.

! The pump unit installed outdoors should be protected from rain by a roof.

! Sufficient safety distance must be kept between the pump unit and any passing people. To ensure the safety of the operator or any other interested party the positioning of the pump should be performed taking into consideration possible ruptures of the parts or leakages and splashes of corrosive liquid under pressure.

! Before installing the pump unit, make sure that the switch is in the "zero" position (OFF) and disconnect the cables from the power supply to avoid the accidental operation of rotating parts.

NOTE: Install the pump horizontally with the discharge port on the top.

NOTE: If the pump unit is installed in a raised position, take any measures necessary to prevent it or any of its parts from falling over or down whilst in operation. The pump unit must be securely fastened to a firm baseplate. In addition, the installation place should be provided of facilities allowing the secure access to the pump unit during installation and maintenance works.

4.2 SUPPORT BASEPLATE AND FOUNDATIONS

The support baseplate must be made using suitable materials to guarantee the stability of the support and its surrounding area. Foundations in reinforced concrete laid on solid ground are highly recommended. The baseplate must be positioned horizontally, checked using a spirit level and fixed using SS 316 stainless anchor bolts. In case of misalignment between the pump unit and pipes is recommended to use metal shims (SS 316) or the regulation system (if provided) to even out any differences found when making the connection.

! Before putting the pump unit into position, check that the foundation is clean, level and solid, after which carefully rest the baseplate on the foundation so as to prevent misalignment of the pump axis.

! The walking surfaces should be non-slip material.

NOTE: The area of the foundations must be greater than the baseplate.

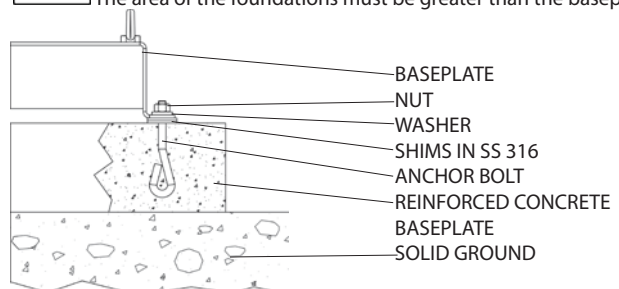



ILLUSTRATION 4.2.1: Example of support baseplate and foundation.

4.3 ALIGNMENT OF THE PUMP UNIT

All pump units are aligned by the manufacturer. However the alignment may be affected during transport. For this reason it is required to realign the pump unit after the installation.

NOTE: It is recommended to check the sense of rotation before align the pump unit (see paragraph 5.1).

NOTE: It is recommended to align the pump unit after install it in the system.

 The alignment operations must be always carry out with the electric power supply and terminals disconnected.

 After the alignment procedure must be always assembled the coupling guards. All its parts must be assembled before the start-up of the pump.

 Incorrect alignment may cause leakages of oil from the rear gasket of the frame.

The best way to check the alignment is by the electronic devices. If these are not available, traditional methods (by ruler or by comparator) could be used.

The procedure to check the alignment using a calliper is listed below:

1. Check with a calliper, ruler or calibrated gauge that the distance between the two half-couplings is equal at the four points measured on the circumference.
2. Rest a ruler on the two parts of the coupling to check if the distance between these parts and the shaft is equal at every point.

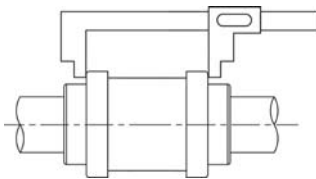

Illustration 4.3.1: Checking the distance between the two half couplings.

The procedure to check the alignment using a comparator is listed below:

1. Rotate the two half-couplings together manually, keeping the instrument stable at the same point (on the edge of the coupling).
2. Repeat the operation, rotating the coupling by 90°.

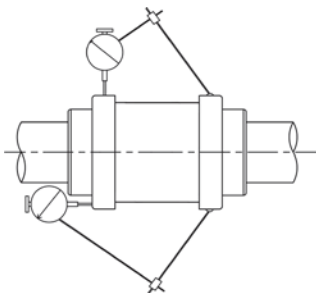
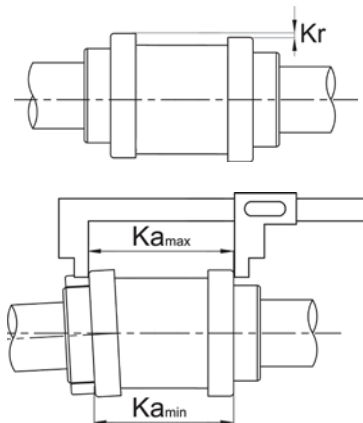

Illustration 4.3.2: Checking using a comparator.

If misalignment is found between the two half couplings, the drive should be aligned using the baseplate adjustment system (see paragraph 6.16).

The unit alignment process must be repeated until the dimensional values measured on the coupling fall within the tolerance values indicated in the following tables 4.3.3 and 4.3.4.



The ΔKa value shown in tables 4.3.3 and 4.3.4 is obtained using the below formula:

$$\Delta Ka = Ka_{min} - Ka_{max}$$

Group (see table 2.1.7.1)	Motor kW (2 poles)	Kr max.	ΔKa max
I	From 1.1 to 22	0.1	0.3
II	From 1.5 to 30		
	From 37 to 55	0.14	
	From 75 to 90	0.3	0.4

TABLE 4.3.3: Maximum coupling misalignment values for pump with 2-pole motor.

Group (see table 2.1.7.1)	Motor kW (4 poles)	Kr max.	ΔKa max
I	From 1.1 to 22	0.1	0.3
II	From 1.5 to 30		
	37	0.14	
III	From 45 to 90	0.3	
	From 11 to 30	0.1	0.4
	37	0.14	
From 45 to 110	0.3		

TABLE 4.3.4: Maximum coupling misalignment values for pump with 4-pole motor.

4.4 PIPING

The design of the piping system has a direct effect on the operation of the centrifugal pump. Due consideration must be given to the size of the suction reservoir and both the suction and discharge piping.

NOTE: Check that the pump unit is insulated from any external source of vibration. If the pump unit is subject to vibration provide anti-vibration mount.

 Always check the chemical resistance of the seals to the pumped liquid.

The suction and discharge pipes, connected to the inlets and outlets of the pump, should not produce excessive or disproportionate loads. Excessively high forces and moments transmitted by the pipes may cause damage to the pump. Suction and discharge piping should be well supported and firmly fastened in place. This operation is essential and compulsory for ensuring correct operation of the pump.

The maximum allowable forces and moments to the pump connections are given below (see table 4.4.1 and 4.4.2). Higher values should not be applied to the pump.

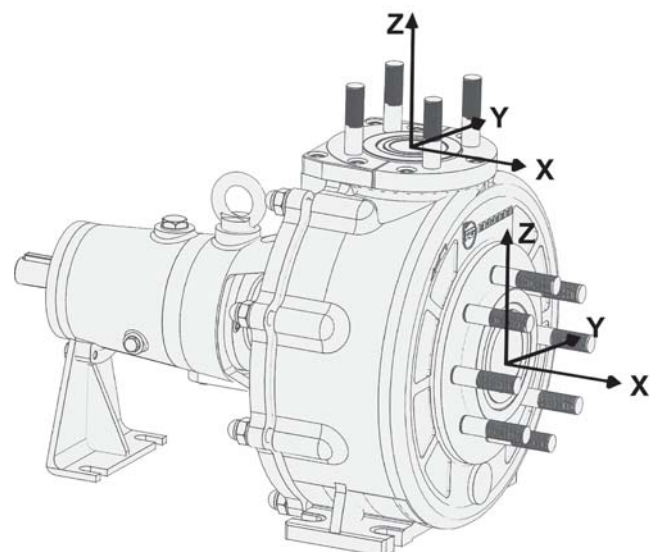

Forces (N) and Moments (N/m) on suction branch								
DN	Fy	Fz	Fx	ΣF	My	Mz	Mx	ΣM
50	735	661	808	1274	490	563	686	1004
65	906	833	1029	1617	539	588	735	1078
80	1102	1004	1225	1935	563	637	784	1151
100	1470	1323	1641	2572	612	710	857	1274
125	1739	1568	1935	3038	735	931	1029	1494
150	2205	1984	2450	3846	857	1004	1225	1788
200	3360	3024	3752	5852	1288	1484	1820	2688
250	4172	3780	4676	7308	1764	2044	2492	3668

TABLE 4.4.1: Forces (N) and Moments (N-m) on suction branch.

NOTE 1: All values of forces and moments are given for the basic material (Polypropylene) and for temperature of 20°C applied to a new pump unit provided by Affetti and firmly anchored to a solid ground. For different conditions contact the manufacturer.

NOTE 2: ΣF and ΣM are the vector sums of the forces and moments.

Forces (N) and Moments (N/m) on discharge branch								
DN	Fy	Fz	Fx	ΣF	My	Mz	Mx	ΣM
32	416	514	441	808	367	416	539	784
40	490	612	539	955	441	514	637	931
50	661	808	735	1274	490	563	686	1004
65	833	1029	906	1617	539	588	735	1078
80	1004	1225	1102	1935	563	637	784	1151
100	1323	1641	1470	2572	612	710	857	1274
125	1568	1935	1739	3038	735	931	1029	1494
150	1984	2450	2205	3846	857	1004	1225	1788
200	3024	3752	3360	5852	1288	1484	1820	2688

TABLE 4.4.2: Forces (N) and Moments (N-m) on discharge branch.

NOTE 1: All values of forces and moments are given for the basic material (Polypropylene) and for temperature of 20°C applied to a new pump unit provided by Affetti and firmly anchored to a solid ground. For different conditions contact the manufacturer.

NOTE 2: ΣF and ΣM are the vector sums of the forces and moments.

NOTE:

The pump must not be used to support the piping.



It must always be checked the parallelism between the pipe and the pump flanges. Incorrect positioning of these parts could cause forced unnatural alignment of the various manifolds connected, which could subsequently cause leaks from the gaskets or even cracks in some sections of piping.

4.5 SUCTION PIPING

Sizing of the suction piping is very important. Many problems connected with the operation of centrifugal pumps are caused by incorrect suction conditions.

NOTE:

Size the suction piping taking into account the NPSH required by the pump so that it is at least 1m lower than the plant's NPSH available.

Follow the general instructions given below:

- The suction piping should be as short and straight as possible and should have an ascending gradient of 1% toward the pump in suction conditions or descending gradient of 1% toward the pump in flooded conditions.
- Support the piping using brackets built with or coated in material resistant to contact with the liquid and vapours.
- The diameter of the suction pipe must be selected so that a flow velocity of 2,5 m/s of water is not exceeded. In case the diameter of the suction pipe is greater than the suction port install an eccentric reducer before the pump.
- In suction conditions determinate the maximum suction height from the lowest liquid level in the suction tank. Take also into account the viscosity, degree of encrustation and temperature of the liquid.
- Avoid elbows, bottlenecks, sudden reductions or obstructions of any

kind. Install only wide radius bends.

- Never fit an elbow directly to the suction port of the pump.
- Avoid any high spots that could create air pockets in the suction pipe.
- Install a gate valve in case of flooded condition of the pump. Maintain the gate valve fully open during the operation. Close it only in case of inspection of the pump.
- Avoid any air infiltration in the suction pipe set carefully the joints between the connections.
- Install a strainer at the end of the suction pipe to prevent foreign matter infiltration in case solid particles are in the liquid. The strainer must be periodically cleaned to prevent restriction.
- Maintain the end of the filling and suction pipes in the suction tank always submerged (see plant recommendations on pages 15-17).
- Maintain a minimum distance between the end of suction pipe and the bottom of the suction tank (see plant recommendations on page 15-17). The distance must be more than 0,5 meter in case of solids particles or mud are on the bottom of the tank.
- Fit a baffle walls into the suction tank to prevent infiltrations or vortices in the suction piping.
- Monitor the minimum level of liquid contained in the priming tank (if provided), preferably using a level probe connected to a solenoid valve for filling up any liquid shortages in the suction tank.
- Install the recommended fittings according to the paragraph 4.9.
- Fit the recommended instrumentations according to the paragraph 4.10.

4.6 DISCHARGE PIPING

A check valve and gate valve should be fitted on the discharge piping, together with performance and temperature monitoring instrumentation.

Follow the general instructions given below:

- Support the piping using brackets built with or coated in material resistant to contact with the liquid and vapours.
- Design the discharge pipe calculating the friction losses. Take also into account the viscosity, degree of encrustation and temperature of the liquid.
- The diameter of the discharge pipe must be selected so that a flow velocity of 5 m/s of water is not exceeded. Install an eccentric expansion after the pump if the diameter of the discharge pipe is greater than the discharge port.
- Avoid elbows, bottlenecks, sudden reductions or obstructions of any kind. Install only wide radius bends.
- Never fit an elbow directly to the discharge port of the pump.
- Avoid any high spots that could create air pockets in the discharge pipe.
- Install an air vent piping between the pump and the check valve. The end of the pipe should be open to the atmosphere.
- Fit a drainage line if the liquid might freeze and drain the liquid before each stoppage.
- Install a flushing system to flush the pump before maintenance works.
- Install the recommended fittings according to the paragraph 4.9.
- Fit the recommended instrumentations according to the paragraph 4.10.

4.7 FILLING PIPING

The filling system is used to fill the suction pipe and the pump in suction conditions with the required amount of liquid before the start-up. The filling system should have a gate valve to isolate the pump and a strainer before the filling port (see plant recommendations on page 15-17).



The gate valve should be always maintained closed during the operation.

NOTE:

The strainer should be cleaned periodically.



Fluid leakages may occur during routine cleaning or replacement of the filter. These operations must be carried out when the pump is not in operation and using appropriate safety equipment.

4.8 DRAINAGE PIPING

The manufacturer provides on request a threaded drainage hole on the lowest area of the casing, with a gaskets and a plug. Belong to the user the responsibility to connect a drainage system to the casing. The drainage system

(not provided by the manufacturer) should be used to evacuate the liquid from the casing (after the shutdown) or the drip-pan of the baseplate (in case of leakages) to a chemically resistant reservoir. The drainage system should be connected to the casing and should have a gate valve to isolate the pump (see illustration below or in the plant recommendations on page 15-17). The same recommendations should be followed for the drip-pan of the base.

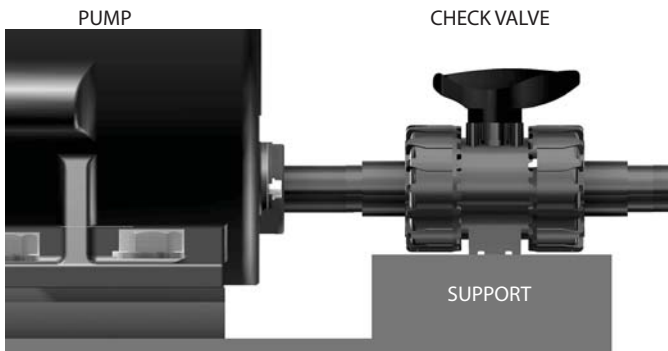

NOTE: The drainage hole on the casing and the drip-pan in the baseplate are provided on request.

 The drainage piping and fittings should be made of the same material of the threaded connection.

 The gate valve should be always maintained closed during the operation.

4.9 FITTINGS

To guarantee correct operation in safety conditions the piping should be equipped with the below fittings:

Recommended fittings		
Fitting	Use	Location
Bracket	To support the pipe.	All piping lines.
Strainer	To reduce the quantity of solid particles.	At the end of the suction pipe.
Eccentric reducer	To avoid air pockets.	Before the suction port.
Gate valve	To isolate the pump in case of inspection.	In the suction line.
Flow conditioner	To minimize swirl and turbulence.	In the suction piping, after the gate valve and at least 5 DN from the suction port.
Strainer	To reduce the quantity of solid particles.	After the gate valve and before the filling port.
Gate valve	To isolate the pump during the operation.	In the filling line.
Gate valve	To isolate the pump in case of inspection.	In the drainage line.
Eccentric expansion	To avoid air pockets.	After the discharge port.
Check valve	To protect the pump from water hammer and to avoid the emptying of the discharge pipe after shutdown.	In the discharge line between the pump and the gate valve.
Gate valve	To regulate the pump performance.	After the check valve.
Gate valve	To exclude the air during the priming process.	In the air vent piping.

TABLE 4.9.1: Recommended fittings in the piping.

 Carefully follow the manufacturer's use and installation instructions for all of the fittings.

NOTE: In order to reduce the pressure losses, the internal diameter of fittings and piping should be the same.

4.10 CONTROL INSTRUMENTS

To guarantee correct operation the piping should be equipped with the below instruments:

Recommended instrumentation		
Instrument	Use	Location
Minimum level probe	To verify the reaching of the minimum level of liquid.	Into the suction tank.
Vacuum gauge	To verify the suction pressure in the suction pipe.	Twice the diameter of the suction port far from the pump.
Thermometer	To check the temperature of the liquid.	In the suction line.
Thermometer	To check the temperature of the liquid.	In the discharge line.
Pressure gauge	To measure the operating pressure.	Twice the diameter of the discharge port far from the pump and before the check valve.
Flow meter	To measure the operating flow.	After the gate valve in discharge line.
Load monitor	To prevent dry running.	Connected to the motor.
Switch (ON/OFF)	To start and stop the pump.	Control panel.
Emergency switch	To stop the operation of the pump in case of failure.	Control panel.
Wattmeter or Ampere-meter	To monitor power absorption.	Control panel.

TABLE 4.10.1: Recommended control instruments in the piping.

 Carefully follow the manufacturer's use and installation instructions for all of the auxiliary control instruments.

4.11 FINAL CHECK

1. Check that the bolts has been tightened correctly .
2. Check that the end caps have been removed from the suction and discharge flanges of the pump.
3. Check the parallelism between the flanges of the pipe and flanges of the pump.
4. Check the suction and discharge flanges has been tightened correctly.

4.12 CONNECTION OF THE ELECTRIC MOTOR

 **DANGER** All electrical connections must be made by a qualified electrician in accordance with EN 60204-1. National or local regulations in force must be observed.

NOTE: An alarm system (visual or audio) must be fitted to warn the user in the event of a possible fault connected with the power supply or electric motor.

 **CAUTION** Avoid any electrical, hydraulic or mechanical overloading. Operations to be performed before starting the equipment:

- Check that the motor has been connected in compliance with the manufacturer's instructions.
- Check that the earthing connection complies with local regulations.

- Check the tag plate on the motor to ensure that the power supply is correct.
- Check the electric motor has been installed at room temperature, avoiding damp and dusty environments.
- Check the bottom part of the motor is sufficiently free, in proportion to the size of the motor to ensure free air circulation, essential for cooling.
- Install a switch (ON/OFF) and an emergency switch according to the regulation in force.
- Install a soft-start or inverter for motors larger than 11 kW.



If the pump is installed outdoor, waterproof the wiring to protect the electrical connections from rainwater.

Three phase motors can be connected “Star” or “Delta”. Star connection is obtained by connecting together the terminals W2, U2, V2 and supplying the terminals U1, V1, W1. Delta connection is obtained by connecting the end of a phase with the beginning of the following one.

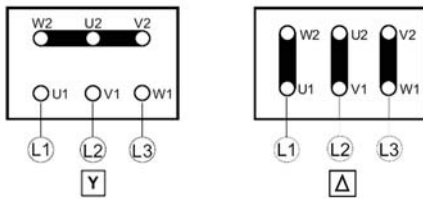

ILLUSTRATION 4.12.1: Electrical connections of the motor.

4.13 CONNECTION OF THE INTERNAL COMBUSTION ENGINE

The user manual for the combustion engine is supplied with the pump. If the engine manual has not been provided, contact the manufacturer immediately. The user should read the instructions carefully and get to know the operations described. By not doing so he may place at risk his own health and safety and that of anyone else in the vicinity of the pump unit.



The responsibility to provide protections for the hot parts of the pump unit belong to the user.

Some important instructions are given here below:

- The fuel to be used is DIESEL. Never use other liquids or fuels.
- Before starting the engine check the level of the oil and the cooling liquid in the radiator.
- Check that the internal combustion engine rotates in the same direction as the pump.
- Every 350 working hours, check that the bolts for the pump are tight.

Some important instructions related to safety are given here below:

- The engine may be used or mounted on a pump unit only by personnel suitably trained in its operation and aware of the dangers involved. This is particularly true for standard and, above all, special maintenance work. For special maintenance contact personnel trained specifically by the manufacturer.
- The manufacturer declines all responsibility for accidents or for failure to comply with the requirements of law if changes are made to the engine's functional parameters or to the fuel flow rate adjustments and speed of rotation, if seals are removed, or if parts not described in the operating and maintenance manual are removed and reassembled by unauthorized personnel.
- Do not start the pump unit in closed or poorly ventilated environments. The internal combustion process generates carbon monoxide, an odourless and highly toxic gas, so spending too long a time in an environment where the engine discharges its exhaust products freely can lead to loss of consciousness and even death.
- The engine may not be used in environments containing flammable materials, explosive atmospheres or easily combustible powders.
- To prevent the risk of fire, keep the machine at a distance of at least one metre from buildings or other machines.
- Fuel is flammable, so the tank must be filled only when the engine is turned off. Dry carefully any fuel that may have spilled, remove the fuel container and any cloths soaked in fuel or oil, check that any sound-absorbing panels made of porous material are not soaked with fuel or oil, and make sure that the ground on which the machine is located has not absorbed fuel or oil.
- Before starting, remove any tools that have been used for carrying out main-

tenance work to the engine and/or the pump unit and check that any guards removed have been replaced. In cold climates it is possible to mix kerosene with the diesel fuel to make the engine easier to start. The liquids must be mixed in the tank by pouring in first the kerosene and then the diesel fuel. Consult the manufacturer technical office for mixture proportions. Petrol may not be used because of the risk of it forming flammable vapours.

- During operation the surface of the engine reaches temperatures that may be dangerous. Avoid in particular all contact with the exhaust system.
- Before carrying out any work on the engine, turn it off and allow it to cool down. Do not perform any operation while the engine is running.
- The liquid cooling circuit is under pressure. Do not carry out any checks before the engine has cooled down, and even then open the radiator cap or the expansion tank cautiously. Wear protective clothing and glasses. If there is an electric fan, do not approach the engine while it is still hot as the fan may come on even when the engine is not running. Clean the cooling system with the engine turned off.
- While cleaning the oil bath air filter, check that the oil is disposed of in such a way as not to harm the environment. Any filtering sponges in the oil bath air filter should not be soaked with oil. The cyclone pre-filter cup must not be filled with oil.
- Since the oil must be emptied out while the engine is still hot (approx. 80°C), particular care should be taken in order to avoid burns. In any case make sure that oil does not come into contact with your skin because of the health hazards involved.
- Check that the discharged oil, the oil filter and the oil contained in the oil filter are disposed of in such a way as not to harm the environment.
- Close the fuel tank filler cap carefully after each filling operation. Do not fill the tank right up to the top, but leave sufficient space to allow for any expansion of the fuel.
- Fuel vapours are highly toxic, so fill up only in the open air or in well ventilated environments.
- Do not smoke or use naked flames while filling.
- Take care when removing the oil filter as it may be hot.
- The operations of checking, filling up and replacing the cooling liquid must be carried out with the engine turned off and cold. Take particular care if liquids containing nitrites are mixed with others not containing these compounds as this may give rise to the formation of nitrosamines which are a health hazard. The cooling liquid is polluting, so dispose of in a manner that does not damage the environment.
- During operations which involve access to moving parts of the engine and/or removal of the rotary guards, disconnect and insulate the positive cable of the battery so as to prevent accidental short circuits and activation of the starter motor.
- Check the belt tension only when the engine is turned off.
- In order to move the engine simultaneously use the eyebolts fitted for this purpose by the manufacturer. These lifting points are however not suitable for the entire pump unit, so in this case use the eyebolts fitted by the manufacturer.
- To prevent accidental starting remove the ignition key of the engine after the shut-off of the pump.



All of the safety instructions are contained in the engine user manual.

4.13.1 Starting the engine

Insert the ignition key, turning it partially to the right until the LEDs switch on. When the yellow LED switches off, turn the key further to the right until the engine starts. Allow the engine to idle for at least 15 min, keeping the accelerator lever fully to the right then, very gradually, move the lever to the left until the required performance is reached and secure it there by tightening the knob on the control support. If the pump's flow rate and head values correspond to the engine's maximum rpm, secure the lever in position using the safety pin.

4.13.2 Removing the engine's hood



To protect the health of the maintenance operator, the hood should only be removed when the engine is switched off and cold.













The removal procedure is as follows:

1. If there is an outside pipe connected to the end of the silencer, remove it.
2. Unhook the hooks on the side of the hood.
3. Attach slings to the ringbolt in the upper part of the hood.
4. Lift the hood vertically.

4.14 EXAMPLES OF INSTALLATION

The following is a list of fittings, instruments or indications to be applied in the plant as shown in the examples on pages 15-17.

NOTE: The warning symbol  indicates the equipment and fittings needed for safety requirements.

No.	Description
DN	The diameter of the port of the pump.
DN1	The diameter of the pipe.
A	The minimum distance between the end of suction pipe and the bottom of the reservoir.
B	The minimum submergence of liquid of the suction pipe into the reservoir
C	The minimum distance between the pipes and the walls of the reservoir.
E	The minimum distance between the suction pipe and the filling pipe in the reservoir.
01	SUCTION PIPE conveys liquid to the pump. In suction conditions, it should be as short and straight as possible and have an ascending gradient of 1% toward the pump while in flooded conditions it should have a descending gradient of 1% toward the pump. The flow velocity should not be higher than 2,5 m/s.
02	 BRACKET supports the piping preventing excessive loads on the branches of the pump. It should be built with or coated in material resistant to contact with the liquid and vapours.
03	 DRAINAGE PIPE conveys the liquid evacuated from the pump to the reservoir. The end of the pipe should be open to the atmosphere. It is required a gate valve.
04	BY-PASS ensures the pump's minimum flow rate is maintained. It conveys liquid to the reservoir or the suction piping.
05	SUBMERGED TERMINAL is required for the suction pipe and filling pipe in the suction tank or reservoir to prevent the formation of vortices in the piping.
06	WIDE RADIUS BEND has lower pressure losses compared with tight radius bends and prevents the formation of air pockets.
07	 GATE VALVE isolates the pump from the piping.
08	STRAINER reduces the concentration of solid particles in the liquid pumped.
09	DRAINAGE PORT is the terminal of the pump that allows the drainage of liquid (provided on request).
10	FOOT VALVE makes it possible to operate in suction conditions.
11	ECCENTRIC REDUCER prevents the formation of air pockets.
12	VACUUM GAUGE measures the suction pressure.
13	SUCTION PORT is the terminal of the pump that allows entry of the liquid into the casing. It is connected to the suction piping.
14	FILLING PORT is the terminal in the discharge piping that allows the liquid filling of the pump and suction piping.
15	DISCHARGE PORT is the terminal of the pump that allows the exit of the liquid. It is connected to the discharge piping.
16	DISCHARGE PIPE conveys the pumped liquid to a reservoir. The flow velocity should not be higher than 5 m/s.
17	ECCENTRIC EXPANSION prevents the formation of air pockets.
18	PRESSURE GAUGE allows to check the working pressure.
19	 CHECK VALVE protects the pump from water hammer and avoids the emptying of the discharge pipe after shutdown.
20	GATE VALVE (on the discharge pipe) permits to regulate the performance of the pump.
21	FLOW METER allows to check the amount of liquid.
22	FILLING PIPE conveys the liquid to the suction tank or reservoir.
23	 REINFORCED CONCRETE BASEPLATE is required to guarantee stability to the pump.
24	 SOLID GROUND is required to guarantee stability to the pump.
25	EXTERNAL FLUSHING SYSTEM is used to flush or wash the mechanical seal with liquid from an external source.
26	 LOAD MONITOR is used to prevent the dry running of the pump.
27	BAFFLE WALL prevents air or vortices from entering in the suction pipe.
28	 LEVEL PROBE is used to monitor the minimum level of liquid.
29	PLUG FOR PROBE is used to apply an external level probe.
30	SOLENOID VALVE is used for filling the self-priming tank.
31	PLUG FOR PROBE is provided for the use of an internal level probe and monitoring the minimum and maximum levels in the tank.
32	CGD / CGD-E PUMP transfers the liquid from a reservoir to another.
33	SELF-PRIMING TANK (provided on request) permits to operate above the level of the liquid inside the suction reservoir.
34	FLOW CONDITIONER minimizes swirl and turbulence in the suction piping.
35	VENT, installed on highest point, allows the evacuation of the air or gas inside the piping or self-priming tank.
36	 POWER SWITCH (ON/OFF) starts or stops the pump without activating or interrupting the other functions of the plant or other machinery.
37	 EMERGENCY SWITCH, installed closed to the machinery, stops the operation of the pump in case of failure. It should be used ONLY if the discharge pipe includes a non-return device. It should be in accordance with the requirements of EN ISO 13850.
38	 WATTMETER/ AMPERE-METER monitors power absorption.
39	 ALARM SYSTEM warns the user in case of fault of power supply or electric motor, absence of liquid in the suction piping or fault of auxiliary flushing.

GENERAL NOTES:

1. The sketches are illustrative. The recommendations refer to a general installation and some information may be missing.
2. All information shown are to be considered useful for the proper functioning of the pump and not for the plant.
3. Information contained in these sketches are deemed reliable. Affetti shall not be held responsible in the event that, despite their efforts to supply exhaustive and consistent information, the contents prove to be insufficient. The purchaser/user must check the information contained in this sketch.
4. Unless otherwise indicated the number of fittings (including brackets) and instruments and their position in the sketches are illustrative.

4.14.1 Installation in suction conditions

NOTE: The installation in suction conditions must be authorized by the manufacturer.

 Never increase the suction heights without the approval of the manufacturer. Maintain the same suction heights or lower than declared on the Order Confirmation or Data-sheet.

 Suction and discharge piping must be tested hydraulically in accordance with the safety regulations before installing the pump.

 The suction piping must be resistant to vacuum conditions.

 The emergency switch should be used ONLY if the discharge pipe includes a non-return device.

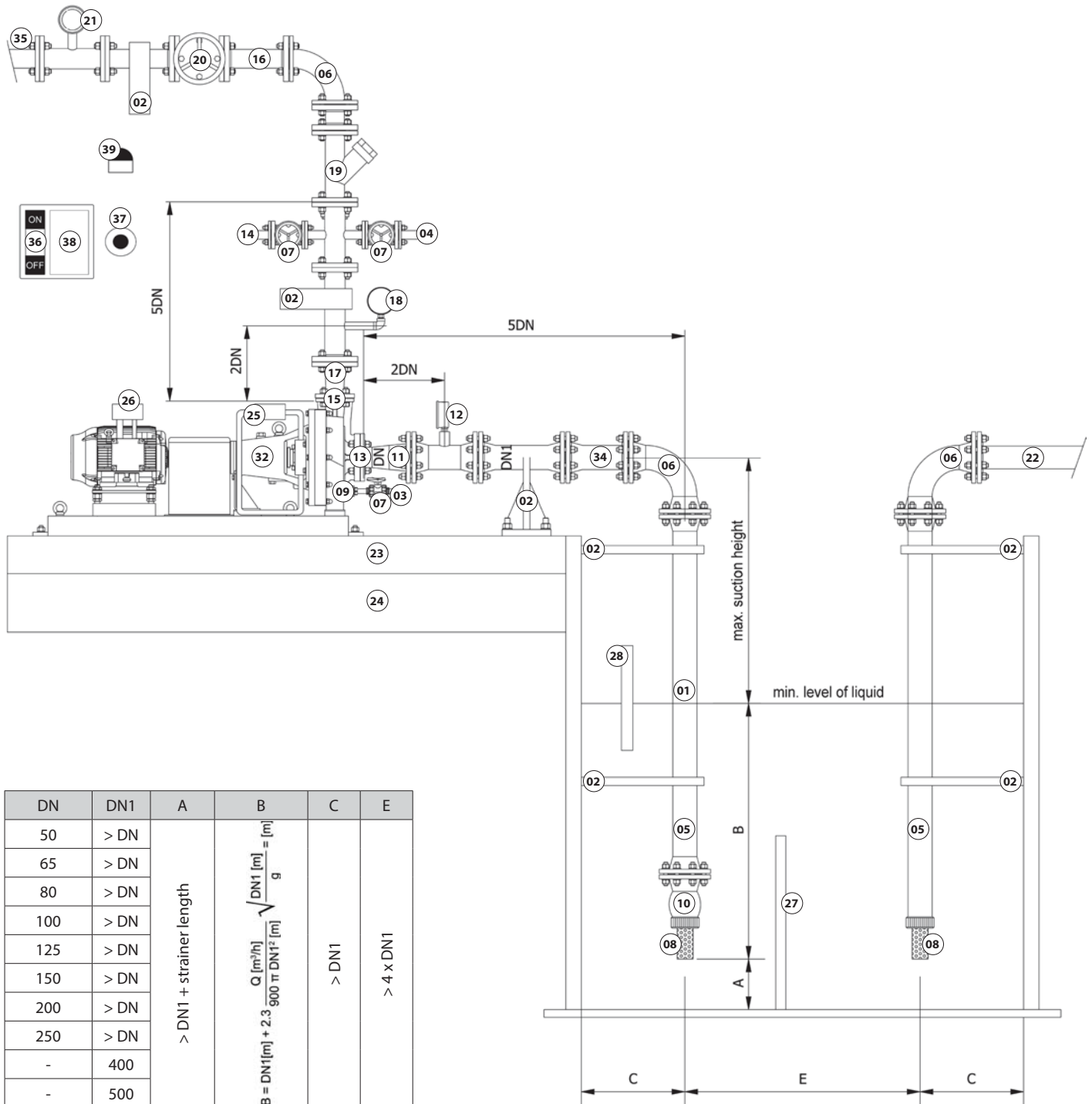

DN	DN1	A	B	C	E
50	> DN	> DN1 + strainer length	$B = DN1 [m] + 2.3 \frac{Q [m^3/h]}{900 \pi DN1^2 [m]} \sqrt{\frac{DN1 [m]}{g}}$	> DN1	> 4 x DN1
65	> DN				
80	> DN				
100	> DN				
125	> DN				
150	> DN				
200	> DN				
250	> DN				
-	400				
-	500				

4.14.2 Installation in suction conditions with self priming tank.

NOTE: The installation of self-priming tank must be authorized by the manufacturer.

NOTE: It is recommended to use a common base for the pump and the self-priming tank.

! Never increase the suction heights without the approval of the manufacturer. Maintain the same suction heights or lower than declared on the Order Confirmation or Data-sheet.

! Suction and discharge piping must be tested hydraulically in accordance with the safety regulations before installing the pump.

! Never reduce the capacity of the self-priming tank.

! Fill the self-priming tank until reaching the maximum level of liquid before starting the pump.

! Monitor the minimum level of liquid in the self-priming tank during the operation.

! The solenoid valve should be connected to the probes inside self-priming tank and should be open when the liquid reaches the minimum level and closed when the self-priming tank is full (even during the operation).

! Check the vacuum pressure in the suction piping is not higher than vacuum resistance of the self-priming tank.

! The suction piping must be resistant to vacuum conditions.

! Forces and moments should not be applied to the nozzle of the self priming tank. Use brackets.

! The emergency switch should be used ONLY if the discharge pipe includes a non-return device.

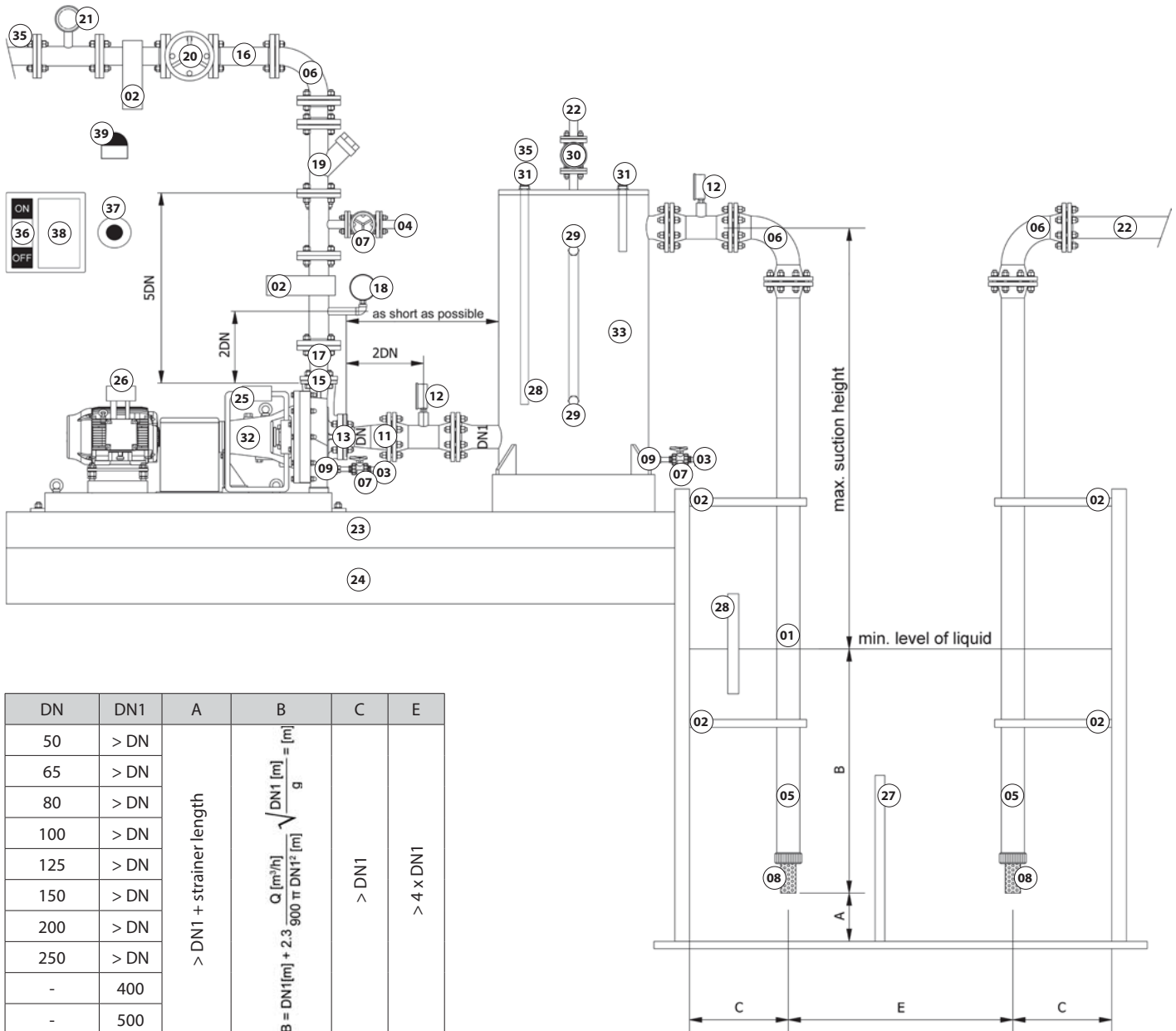

4.14.3 Installation in flooded conditions.

! Suction and discharge piping must be tested hydraulically in accordance with the safety regulations before installing the pump.

NOTE: The minimum distance between the pump and gate valve in the suction pipe should be not less than 5 times the diameter of the suction port.

NOTE: The minimum length of the straight suction pipe should be not less than 10 times the diameter of the suction port.

! The emergency switch should be used ONLY if the discharge pipe includes a non-return device.

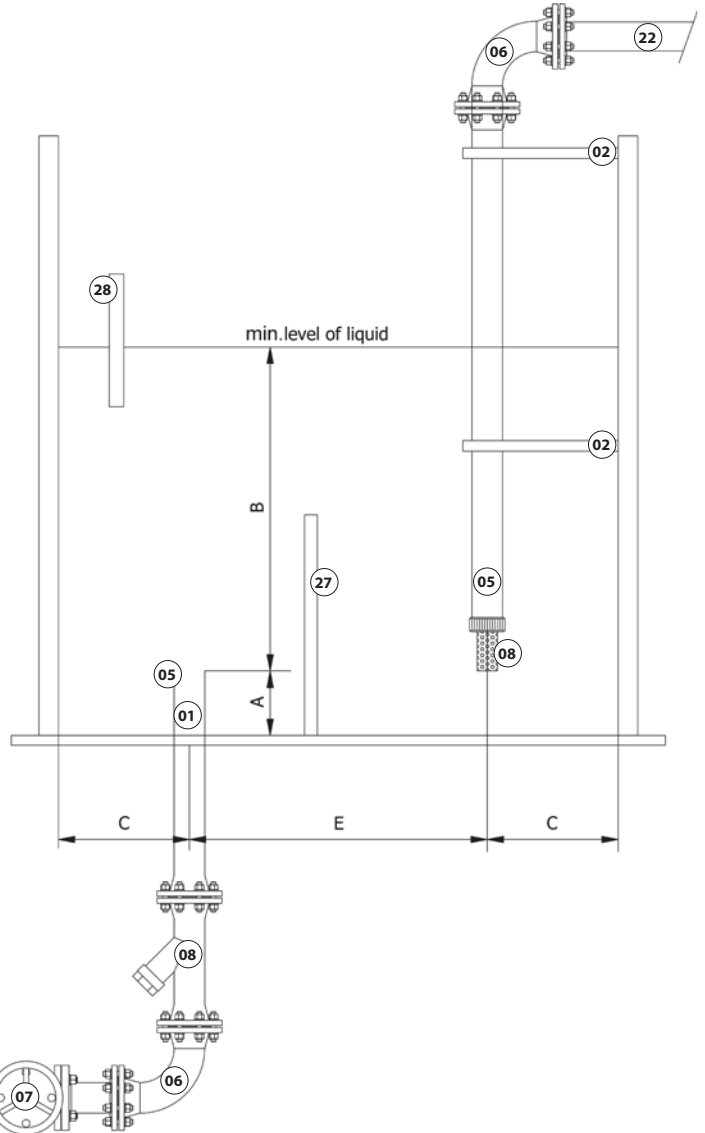
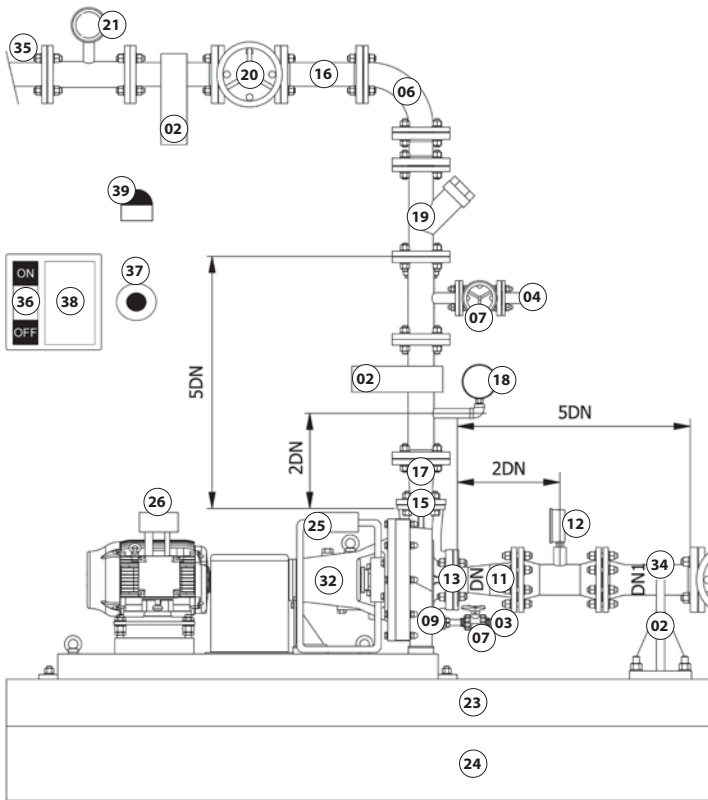

DN	DN1	A	B	C	E
50	> DN	> DN1 + strainer length	$B = DN1 [m] + 2.3 \frac{Q [m^3/h]}{900 \pi DN1^2 [m]} \sqrt{\frac{DN1 [m]}{g}}$	> DN1	> 4 x DN1
65	> DN				
80	> DN				
100	> DN				
125	> DN				
150	> DN				
200	> DN				
250	> DN				
-	400				
-	500				

5.0 OPERATION



The operators should be equipped with appropriate equipment during all operations of this chapter. Rubber boots, anti-acid overalls and a helmet with a protective visor for the face are essential requirements to allow operators to work without risking their physical safety. It is strictly prohibited to insert fingers or other parts of the body into the orifices and various openings. The pump unit is equipped with moving parts. The follow operations must be performed by skilled staff.

5.1 DIRECTION OF ROTATION

The direction of rotation should be checked before the start-up. The direction of rotation is indicated, in permanent form, on the pump unit; clockwise looking from the motor to the pump.

To check the direction of rotation should be followed the below procedure:

1. Set the power switch to the OFF position.
2. Disconnect the electrical cables from the terminal board.
3. Remove the coupling guard (pos. 131).
4. Remove the spacer of the pump coupling (pos. 42A).
5. Assemble the coupling guard (pos. 131).
6. Connect the electrical cables to the terminal board.
7. Set the power switch to the ON position starting the electric motor.
8. Check the direction of rotation is as marked on the pump, watching the rotation of the fan of the motor.
9. If the direction of rotation is wrong invert two phases (procedure to be performed with the power switch in the OFF position).
10. If the direction of rotation is correct, replace the spacer and start the pump.
11. Perform the pump unit alignment (see paragraph 4.3).



The procedure listed above should never performed with cables connected to the electric motor or the spacer of the coupling assembled to the pump.



The operator should never remove the coupling guard or touch the rotating parts during the operation.



The pump should never run in the reverse direction of rotation.

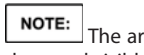

The arrows indicating the direction of rotation should always be clean and visible.

5.2 PRELIMINARY PUMP TESTING

Before the start-up, manually rotate the pump shaft in the direction of rotation by the coupling to make sure that it rotates freely and is free of friction or obstructions. The operation must be performed with electric cables disconnected from the terminal board.

5.3 FLUSHING

If a mechanical seal with external flushing is used, make sure the valve or tap is open before operating the pump and that the instructions given in the chapter 8 concerning quantity, pressure and compatibility of the flushing liquid are complied with.



The threaded connections of the external flushing should be in the same material of the threaded connections of the pump.

5.4 PRELIMINARY MOTOR TESTING

Check all of the electrical connections (see paragraph 4.12) and the direction of rotation (see paragraph 5.1) before the start-up of the pump.

5.5 START-UP

Before starting the pump the following steps should be performed:

1. Check that the support bearings are correctly lubricated.

2. Check the direction of rotation of the motor (refer to the arrow marked on the pump unit).
3. Check that the suction and discharge pipes and gaskets are connected correctly and that all the bolts are well tightened.
4. Close the drainage valves (if provided).
5. Open the external mechanical seal flushing device (if provided). Quantities and operating pressure values related to flushing are specified in in the chapter 8.
6. Fully open the gate valve on the suction piping.
7. Check and flush the suction piping to remove any solid or foreign bodies.
8. In suction conditions fill the pump and the suction pipe completely
9. Check that the foot valve is operating correctly.
10. Turn the pump on using the power switch.
11. Open gradually the gate valve in the discharge pipe (start from 10%).
12. Adjust the duty point regulating gradually the gate valve (discharge pipe).
13. Check the absorption values of the pump unit referring to those marked on the tag plate of the motor and make sure that those values (absorbed power in kW or intensity in amperes) are not exceeded.



The pump must never run dry.



Clean the inside of the pump before the start-up procedure of a inactive or repaired unit.



Do not use the suction valve to adjust the flow. The suction valve must always be completely open.



Do not open excessively the discharge valve if it will cause the over-load of the motor. Open the discharge valve according to the duty point and amperage.



Alternate operation of the pump in use with the stand-by pump at weekly intervals.

5.6 OPERATION

Attention should be paid to the following warnings during the pump's operation:

- It is prohibited to work on the pump unit when it is in operation.
- It is prohibited to carry out any work on the motor when connected to the electric power supply.
- Monitor the temperature of the bearings (see tables 5.8.1.1-5.8.1.2).
- Prevent people or things coming into contact with hot parts of the pump unit.
- Make sure that the pump unit does not vibrate and is not excessively noisy (see paragraphs 5.10 - 5.11).



Check during the operation there are not increases in temperature.



The pump unit should never operate with one or some parts damaged. In the event of a fault, turn the pump off and investigate the cause (see paragraph 6.19).



The pump must never run dry.



During the operation check the discharge pressure do not exceed the allowable limit (see paragraph 2.3).



The pump should not operate more than 1 minute with the discharge valve fully closed.



Stop the pump in case of cavitation.

5.7 SHUTDOWN

Close the discharge valve (slowly to prevent water hammer) until reaching the 10% of the flow rate. Turn off the power switch and close completely the discharge valve. Later close the valve of the external flushing (if provided).

 When the pump is stopped without a non-return device on the discharge pipe the liquid will flow through the pump to the suction source.

NOTE: Start and stop the pump frequently will damage the pump early.

NOTE: Do not use a solenoid valve to stop the pump unit.

NOTE: When the ambient temperature falls below freezing point, the liquid tends to crystallize, or in case of storage the pump and the piping must be drained and washed after the shut-off of the pump.

NOTE: Operation of the inactive pump should be checked on a regular basis.

NOTE: If the pump remains inactive for a long period of time, rotate the pump shaft (via coupling) at least 5 turns every week. See paragraph 3.4.

5.8 TEMPERATURES

The working temperature of the pump is indicated in the data sheet and in the order confirmation.

NOTE: The temperatures limits may vary changing the pumped liquid or its concentration. In order to know the temperature limit for the pumped liquid contact the manufacturer.

 If the operating temperature exceeds 60°C the pump must carry a warning notice to alert personnel working in the area.

 The personnel working close the pump unit must avoid any contact with the hot parts.

5.8.1 Temperature of bearings

Measurement of the temperature of both bearing at regular intervals, compared against the values provided by the manufacturer measured during the production test, will highlight any changes in the operating conditions, wear or imbalance of the rotating parts, installation conditions that do not meet the requirements for correct assembly of the pump to the plant or a general malfunction of the entire system requires immediate intervention.

Group (see table 2.1.7.1)	Range of bearing temperature with 2950/3500 RPM
I	50 - 65 °C
II	50 - 70 °C
III	50 - 75 °C

TABLE 5.8.1.1: Maximum bearing temperatures with 2950/3500 RPM.

Note: the bearing temperatures specified were measured during operation with water at ambient temperature at the pump's best efficiency point (BEP) reached with maximum diameter of impeller and lubricating the bearings with synthetic oil 68 (PAO).

Group (see table 2.1.7.1)	Range of bearing temperature with 1480/1780 RPM
I	50 - 60 °C
II	50 - 65 °C
III - IV	50 - 70 °C

TABLE 5.8.1.2: Maximum bearing temperatures with 1480/1780 RPM.

Note: the bearing temperatures specified were measured during operation with water at ambient temperature at the pump's best efficiency point (BEP) reached with maximum diameter of impeller and lubricating the bearings with synthetic oil 68 (PAO).

 Temperatures at least 10°C higher than those specified in tables 5.8.1.1 and 5.8.1.2 indicate a state of alarm that must be reported to the manufacturer.

NOTE: The maximum temperature of the bearing should not exceed 110 °C.

5.9 FLOW RANGE

The choice of the type of pump, impeller and motor is made at the time of offer based on data provided by the customer related to flow rate and head. The user should strictly observe the operating conditions mentioned on the data sheet, especially related to the data concerning flow rate, head and the liquid pumped for which the pump was intended. The pump should be used in accordance with the percentages shown in the paragraph 2.4. In the event that the operator needs to use the pump in a different point compared to that shown on the data sheet contact the manufacturer

5.10 VIBRATION LEVEL

Measurement of vibration performed at regular intervals, compared against the values provided by the manufacturer measured during the production test, will highlight any changes in the operating conditions, wear or imbalance of the rotating parts, installation conditions that do not meet the requirements for correct assembly of the pump to the plant or a general state of disrepair of the whole system.

Working condition	Max. vibration level		
	Motor ≤ 7,5 kW	Motor ≤ 30 kW	Motor > 30 kW
Normal	3 mm/s	4,5 mm/s	6 mm/s

TABLE 5.10.1: Vibration level.

Note: the limits above are for new pump unit provided entirely by the manufacturers and carefully anchored in accordance with the instructions given in this manual. Used pump unit may have values of vibration exceeding the limits.

NOTE: The installation of anti-vibration mounts is recommended.

5.11 NOISE LEVEL

Generally the pump unit does not exceed the 80 dB. However, the noise level could increase due a sum of factors, as the duty point, size of motor, type and material of pipeworks and the structure of the building.

Approximate values are shown below:

Motor nominal power [kW]	Noise level in dB(A)			
	1480 RPM	1780 RPM	2950 RPM	3500 RPM
1.5	58	59	63	64
2.2	60	61	66	67
3	62	63	68	69
4	63	64	69	70
5.5	65	66	71	72
7.5	66	67	72	73
11	68	69	74	75
15	69	70	75	76
18.5	70	70.5	76	77
22	71	72	77	78
30	72	73	78	79
37	73	74	79	80
45	74	75	80	81
55	75	76	80.5	81.5
75	79	77	81	82
90	76	77.5	82	83
110	77	78	82.5	83.5
160	79	80	84	85
200	80	81	85	86

TABLE 5.11.1: Pump unit's sound pressure.

NOTE: The noise values were measured during operation of the pump driven by an electric motor, pumping water at ambient temperature, cavitation free, at the best efficiency point in our test room. Operational factors such as the flow rate, type of pipework and acoustics of the building can increase the pump's sound pressure. The values specified are therefore subject to a tolerance of +5 dBA and are not guaranteed.

 Acoustic emissions should be lower than the maximum levels permitted by local regulations. If the noise level exceeds the safety values, some action that can be taken to protect the health of personnel exposed to sound pressure generated by the pump are indicated here below:

Sound pressure	Action to be taken
Less than 70 dB	No particular action
Greater than 70 dB	Provide personnel working close to the pump with personal protective equipment.
Greater than 80 dB	Signs must be put up at the entrance to and within the area warning that it is a hazardous area due to the high sound pressure level. Anti-noise head phones must be worn. The pump unit must be equipped with a soundproof covering. Anti-noise head phones must be worn.

TABLE 5.11.2: Actions to protect the health of the personnel.

 If the pump is driven by an internal combustion engine the noise level may exceed 80 dB. If this is the case, the pump unit should be provided with a soundproof covering and personnel must use PPE to protect them from the noise.

 **CAUTION** Excessive noise from the motor could be a sign that the bearings are worn and excessive noise from the pump could be a sign of cavitation (cavitation typically produces a booming sound, as if the liquid being pumped contains gravel).

6.0 MAINTENANCE

 **CAUTION** **The operators should be equipped with appropriate equipment during all operations of maintenance. Rubber boots, anti-acid overalls and a helmet with a protective visor for the face are essential requirements to allow operators to work without risking their physical safety. It is strictly prohibited to insert fingers or other parts of the body into the orifices and various openings. The pump unit is equipped with moving parts. These operations must be performed by skilled staff.**

6.1 PREVENTIVE MAINTENANCE

Check the characteristics of the pumped liquid (temperature, specific gravity and chemical composition). Check that the flow rate and pressure values comply with the design values and that they have not been subject to change. Make sure that control instruments are fully efficient and they always receives the right signals.

6.2 MAINTENANCE INSTRUCTION

Some instructions for the safety of personnel performing maintenance on the pump unit are given here below:

 Before carry out any maintenance work should be analysed the safety data sheet of the pumped liquid.

 All maintenance operations should be carried out outside of hazardous areas previously allocated for this purpose.

 For loads greater than the manual handling (including spare parts) use a suitable, type-tested hoisting system that is in good condition connected to rings, eyebolts, holes or threaded terminals of the part to lift. Goods must only be handled by suitably trained personnel, according to the relevant regulations in force.

 If the lighting is not sufficient the inspection and all maintenance operations should be performed using portable lamps.

 Any work must be carried out when the pump is not operating. If a switch has been fitted, it must be set to the "zero" (off) position.

 Take precautions to ensure that the pump is not started involuntarily.

 Never touch the pump if the liquid pumped or lubricant exceeds +70°C. Wait until the pump cools down before performing any work.

 If the liquid pumped is hazardous take appropriate safety precautions when performing maintenance work, in accordance with the regulations in force.

 Never spray water or washing liquid on hot parts or components as it could cause thermal shocks.

 **DANGER** If the pump is washed using a water jet, prevent sprays or drops of liquid from entering the terminal board of the electric motor.

NOTE: Replace gaskets and O-rings each time the pump is disassembled.

NOTE: On completion of any maintenance work, for the start-up procedure repeat the steps indicated in the paragraph 5.5.

6.3 DAILY INSPECTION AND MAINTENANCE

Daily monitoring during operation will avoid complications and ensure immediate action can be taken in the event of malfunction.

Inspect the pump unit every time it is used:

1. Check the noise level, vibration, temperature and performance.
2. Check that there are no unexpected leakages of liquid or lubricant.
3. Check the level of lubricating oil.
4. Make sure that the external flushing pressure for the mechanical seal is at least 1 bar greater than the operating pressure.
5. Make sure the pump never operates without liquid.
6. Check the drip-pan of baseplate (if provided) is not full of liquid. In this case, open the valve and empty the drip-pan.
7. Always make sure that the pump unit is properly fastened, checking that all of the screws are tightened correctly.

6.4 SIX-MONTHLY INSPECTION AND MAINTENANCE

Inspect the pump every six months irrespective of whether it has been used or not.

The six-monthly maintenance procedure is as follows:

1. Disconnect the electrical part.
2. Drain the casing of the pump (if the drainage hole is provided).
3. Clean and wash the pump, checking the compatibility of cleaning products used with residues of the liquid pumped. Never use flammable solvents to clean the parts.
4. Disassembly the pump unit (see paragraph 6.14).
5. Check the condition of the mechanical seal.
6. Check if the plastic parts are damaged or worn.
7. Check if there are cavitation traces.
8. Check the alignment of the pump unit (see paragraph 4.3).
9. Replace gaskets and O-rings.
10. If the liquid contains solid particles, check that the suction filter and the foot valve (in suction conditions) are clean.
11. Check the condition of the bolts used to fasten the baseplate and foundation (see paragraph 4.2).
12. Assembly the pump unit (see paragraph 6.15).
13. Make sure that the pump is properly fastened, checking that all of the screws are tightened correctly.
14. Start-up the pump (see paragraph 5.5).

If a fault is found, replace the damaged or worn parts or according to the manufacturer send back the pump to repair (see paragraph 6.13).

 If the pump is used on fluids with solids particles or high temperature may be requested an earlier inspection and maintenance work.

6.5 EXTRAORDINARY MAINTENANCE

Immediate action must be taken in the event that a fault, malfunction or fluid leakage is reported by the operator or signalled by the general electrical panel, stopping the pump according to the shutdown procedure (see paragraph 5.7). The cause of the fault or malfunction must then be analysed, (see paragraph 6.19). It is important to contact the manufacturer if the source or cause of the problem cannot be identified. No work must be carried out on the pump without prior approval from the manufacturer.

 In case of emergency or safety risk for the personnel can be used the emergency switch if a non-return device is included in the discharge piping.

 In the event of leakages of corrosive or hot liquid immediate actions to avoid the any contact, such as the evacuation of the area, must be taken. The corrosive liquid must be removed by authorized companies in accordance with national laws and regulations.

6.6 GRADE OF LUBRICATING OIL

It is very important to ensure that the correct oil level is maintained. An insufficient oil level may result in insufficient lubrication of the bearing causing premature wear. An excessively high oil level could cause the bearing to overheat or lubricant to leak from the sealing rings.

The amount of oil depends on the group or size of the housing:

Group (see table 2.1.7.1)	Quantity of oil
I	130 g
II - III	280 g
III	480 g

TABLE 6.6.1: Quantity of lubricating oil

NOTE: The amount of oil present in the frame must be measured at ambient temperature when the pump is not in operation.

The following types of lubricating oil are recommended:

Oil type	Use	Maximum temperature	Freezing point	Oil replacement
Synthetic 32	Room temperature: 0 / -40 °C	+50°C	-60 °C	3000 hours
Synthetic 68	Room temperature: 0 / +50 °C	+80°C	-40 °C	3000 hours

TABLE 6.6.2: Types of lubricating oil.

NOTE: Vegetable or animal oils should not be used as they tend to become rancid and will eventually corrode the bearing surfaces.

The following types and brands of oil are suitable:

Oil brand	Viscosity 32	Viscosity 68
BP	Enersyn HTX 32	Enersyn HTX 68
Mobil	Eal Hydraulic 32	Rarus SHC 1026
Shell	Naturelle HFE 32	Corena AS 68
Texaco	Cetus PAO 32	Cetus PAO 68
Q8	Suman 32	Suman 68

TABLE 6.6.3: Brand and type of lubricating oil.

Some instructions related to the choice of lubricating oil are given here below:

- It must be totally clean and free from the presence of foreign, solid particles.
- Always take into account the ambient temperature that the pump operates in.
- Avoid mixing together oils of different brands or characteristics.

NOTE: The maximum temperature of the bearing must not exceed 110 °C.

 In case of leakage of lubricant provide immediate cleaning of the parts and the floor according to the safety recommendations.

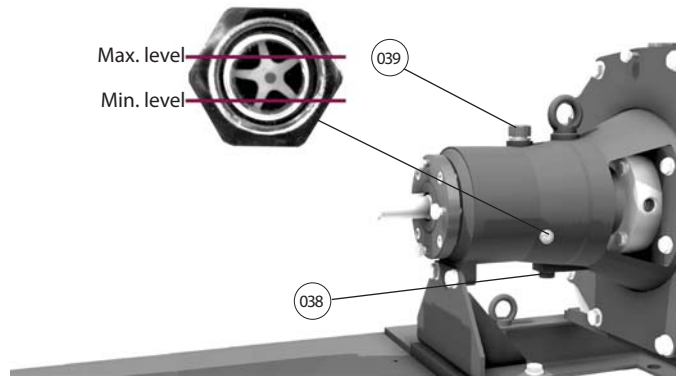

Procedure for topping up oil in the frame:

1. Unscrew the plug (Pos. 039).
2. Pour in the required amount of lubricant. Check that the level is not higher or lower than the required amount.
3. Screw the plug back on (Pos. 039)

Procedure for draining oil from the frame:

1. Position a basin below the plug (Pos. 038).
2. Unscrew the plug (Pos. 038).
3. Wait until all the oil has drained out.
4. Clean up any drips.
5. Screw the plug back on (Pos. 038).

 Make sure that used oil is disposed of in compliance with local regulations and do not dispose of in the environment.

6.7 CRYSTALLIZATION OF PUMPED LIQUID

The crystallization of liquids is a problem that should not be underestimated. The user must obtain the technical data sheet of the pumped liquid from the relevant supplier to identify at what temperature and under what circumstances the crystallization process begins. The manufacturer must be informed of the use of any liquid that has a tendency to crystallise. Failure to declare the required information will invalidate the AFFETTI warranty.

6.8 DRAINING AND CHANGING THE PUMPED LIQUID

The user must request written consent from the manufacturer for any variation in the liquid to be pumped. Different specific gravity or viscosity could affect the suction lift or increase the shaft power and the discharge pressure.

The procedure to be followed when changing the liquid to be pumped is as follows:

1. Stop the pump unit (see paragraph 5.7).
2. Drain completely the casing (if drainage hole is provided) and the suction piping.
3. Clean the pump internally with water or a compatible liquid, taking care with regard to any chemical reactions that could cause irreparable damage to the pump and the operator.
4. Dispose of the rinsing liquid, with due care for the protection of the environment.

 In the event of leakages of corrosive or hot liquid immediate actions to avoid the any contact, such as the evacuation of the area, must be taken. The corrosive liquid must be removed by authorized companies in accordance with national laws and regulations.

 In case of leakage of not corrosive liquid provide immediate cleaning of the parts and the floor according to the safety recommendations.

6.9 DRY RUN OPERATION

The pumps of this series should never dry run. The dry run operation could damage the mechanical seal or the other parts of the pump.

Below are listed situations in which dry run operation could occur:

- Total or partial absence of fluid in the tank.
- Missing or malfunction of the instrumentation to verify the absence of liquid in the piping or in the tank.
- Inefficient maintenance of the filter or foot valve
- Failing of the gate valve in the suction piping.
- The formation of air pockets and cavitation due to incorrect sizing and an inadequate structure of the fittings in the suction piping.

6.10 IMPURITIES CONTAINED IN THE PUMPED LIQUID

The pumped liquid should be clean. It is advisable not pumping liquids with percentages, even low, of solid particles. In case the liquid contains solids particles, the concentration, size and hardness must be declared in the enquiry in order to allow selection of the most suitable solution for the application.

NOTE: Solid particles in the liquid increase the wearing of the internal parts.

NOTE: If the liquid contains solid particles, install a strainer in the suction pipe.

NOTE: If solid particles are being pumped, it is recommended to have mechanical seal faces in Silicon Carbide.

NOTE: Slurry liquid pumping is not possible.

6.11 RECOMMENDED SPARE PARTS

To determine the minimum quantity of spare parts that should be kept available for any replacements that may be required, the user should take into consideration the operating conditions and the number of interchangeable units installed on the plant. In order to know the frequency of replacement for each unit please contact the manufacturer.

The spare parts listed below are always needed on stock for each unit in operation:

No.	Description	No.	Description
008	Impeller	053	Mech. seal
017	Impeller nut	009	Shaft
020, 024, 025, 026, 027, 042, 043, 044, 046, 048, 049, 050, 052, 090, 114, 115	O-rings and gaskets	047	Seal chamber
		010, 112	Bearings
16	Shaft sleeve		

TABLE 6.11.1: Recommended spare parts.

NOTE: Replace gaskets and O-rings each time the pump is disassembled.

To order spare parts should be provided:

- The serial number, name and type of pump (marked on the tag plate).
- Component position number (see on pages 32 - 41).
- Number of pieces required.

NOTE: Spare parts must be manufactured exclusively by AFFETTI. The use of parts not manufactured by AFFETTI will invalidate the pump's warranty and safety certification.

NOTE: Spare parts must be kept in a dry, clean place, away from sources of vibration and at a temperature of between +5°C and +35°C.

6.12 DISPOSAL

Replaced parts or pump units that have reached the end of their working life must be subjected to a careful selection process to separate and dispose the various parts according to their material.

CAUTION Disposal of used or damaged pumps must be done in accordance with laws and regulations by specialized and authorized companies.

6.13 RETURNING OF THE PUMP UNIT

Before returning the pump unit to repair in the manufacturer's factory the pump must be drained completely and cleaned internally with water or a compatible liquid, taking care with regard to any chemical reactions. Rinsing liquid should be disposed according national laws and local regulations.

CAUTION In case the pump is returned with the liquid inside or not completely drained and washed AFFETTI will send back the goods with transport on charge of the user.

6.14 DISASSEMBLY OF THE PUMP UNIT

CAUTION Do not try to disassemble or repair the pump unit by your-self. Disassembly procedure of the pump unit should only be performed by personnel in possession of at least basic mechanical knowledge and skills. Minimum knowledge of the materials used is also needed to provide a better understanding of the pump's characteristics.

CAUTION Never try to remodel the pump unit or change some parts without the authorization from the manufacturer.

Before disconnecting the pump from the plant follow the below procedure:

- Make sure that the pump unit is not in operation.
- In order to avoid any unexpected start-up during the maintenance working disconnect the plug from the electric board and the electric wires from the terminal board of the motor. Carefully isolate the ends.
- Close the suction and discharge valves.
- Wait until the pump unit reaches the ambient temperature.
- Open the draining valve and clean the wetted parts and the drip-pan of the baseplate (if provided) with water or an appropriate liquid and dispose the pump washing solution according to laws and regulations.
- Disconnect the pump unit from the system.

NOTE: Great care must be taken during the disassembly process to prevent damage to internal parts of the pump caused by the incorrect use of pliers and screwdrivers.

NOTE: Place the various components on a bench in the same order in which they are removed and protect them from knocks and dust.

DISASSEMBLY PROCEDURE

NOTE: Identify all of the parts and their codes on pages 32 to 41 before proceeding with disassembly.

CAUTION If provided, pay attention during the disassembly procedure of the drainage and the drip pan of the baseplate. If traces or small quantity of liquid are into the drip pan remove it with care avoiding any leakage of liquid.

TOOLS

CAUTION Damaged or deteriorated tools are dangerous. Use qualified and suitable tools only.

NOTE: Single disassembly operations should be performed only if necessary.

Arrange all of the required tools on a bench:

- A. Straight-nose pliers for external elastic ring
- B. Straight-nose pliers for internal elastic ring
- C. Key for internal hexagon socket screws
- D. Curved-nose pliers for internal elastic ring
- E. Straight-nose pliers for internal elastic ring
- F. Hexagon key
- G. T-handle key for external hexagon socket screws
- I. Belt wrench
- J. Extractor
- K. Rubber mallet



2. Unscrew the screws (Pos. 080, 081, 094, 096, 106) and extract the coupling guard (Pos. 070).

3. Unscrew the screws (Pos. 085, 088) connecting Part C of the coupling (Pos. 082) to Parts B and D.

4. Extract Part C of the coupling (Pos. 082).



5. Extract Part B of the coupling (Pos. 082).

 Before the next step, mark the position of part A of the coupling on the pump shaft. This position should be used to assemble the coupling.

6. Extract Part D of the coupling (Pos. 082).



7. Unscrew the fastening grub screw (Pos. 105) and extract Part D of the coupling (Pos. 082).

8. Unscrew the grub screws and extract Part A of the coupling (Pos. 082) tapping it lightly with a rubber mallet (K).



9. Unscrew the fixing screws of the pump (Pos. 074, 075, 063, 073) and the motor (Pos. 076, 077, 104).

STEP 2 (disassembly of the pump casing)

1. Unscrew (right thread) the casing fastening nuts (Pos. 034, 037).



2. Unscrew the screws (Pos. 030) using the key for internal hexagon socket screws (C) and extract the delivery flange (Pos. 004).



3. Remove the discharge nozzle (Pos. 015) and the O-rings (Pos. 043 and 050).

4. Extract the metal armour (Pos. 003).



5. Extract the pump casing (Pos. 006) and tighten some general purpose screws in the relevant threaded holes in a crosswise fashion.





6. Unscrew (right thread) the impeller nut (Pos. 017) using a pair of straight-nose pliers for the internal elastic ring (E).



7. Unscrew the self-locking nut (Pos. 033 for group 1) or the slim nuts (Pos. 033 for groups 2, 3 and 4).



8. Remove the impeller (Pos. 008) from the shaft (Pos. 009) using an extractor (J).

9. Remove the casing cover (Pos. 007).



10. Remove the fixing screws of the rotating part of the seal (only for JRS and JRS1 mechanical seals).



11. Extract the seal unit (Pos. 016, 053, 060, 041) and the key (pos. 069) fastening the shaft sleeve to the shaft.



12. Extract the stuffing box (Pos. 047) from the casing cover (Pos. 007) pressing with your fingers or tapping lightly with a rubber mallet.



STEP 3 (disassembly of bearing housing)

NOTE: Before to proceed with this step make sure that the bearing housing does not contain oil.

1. Remove the housing covers (Pos. 011, 113).



2. Remove the key fastened to the shaft (Pos. 018).

3. Using a press (if not available use a rubber mallet) fully withdraw the shaft (Pos. 009) from the housing and rear bearing (Pos. 010).

4. Extract the ball bearings (Pos. 010, 112) using an extractor.

BACK PULL OUT

The Back-pull-out unit (bearings housing, shaft, mechanical seal and impeller) can be removed without disconnecting the pump casing from the piping by following the procedure described here below:

1. Remove the coupling guard (Pos. 070) and the fixing screws (Pos. 080, 081).

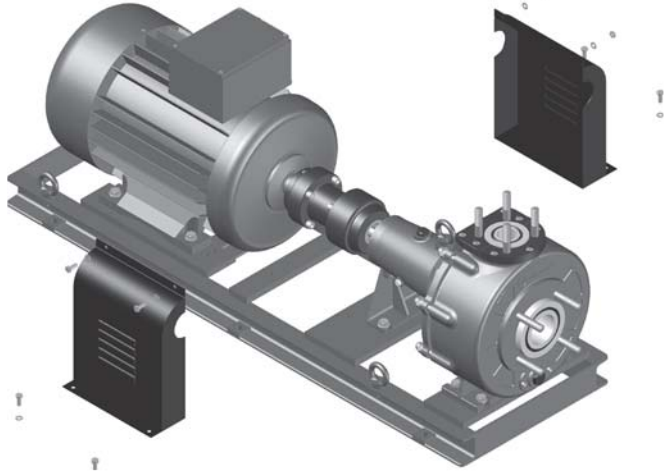

2. Remove the fixing screws (Pos. 085, 088) and the coupling spacer (Pos. 082C).

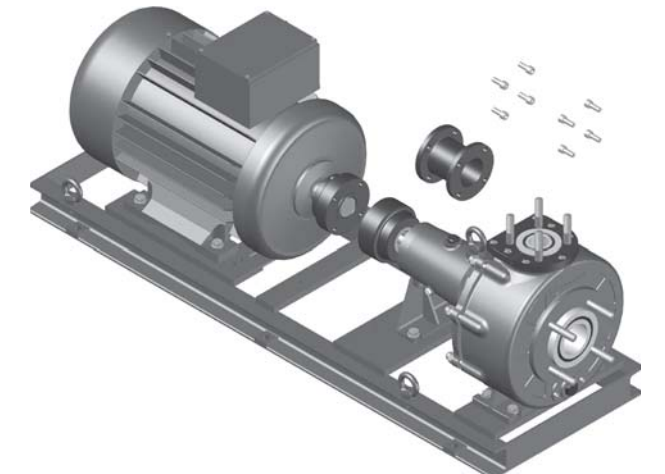

3. Remove the fixing screws (Pos. 034, 037, 074, 075) and extract the pump.

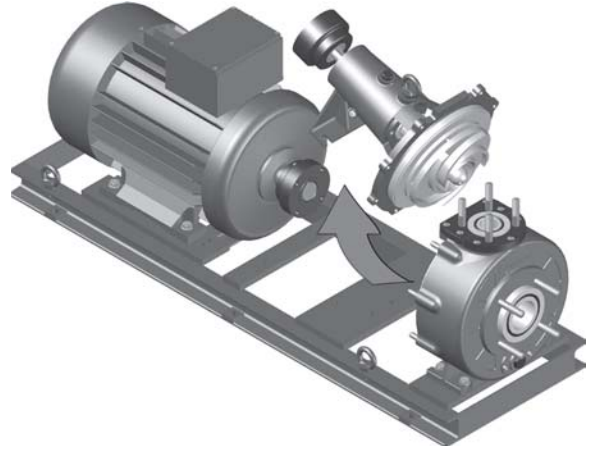

6.15 ASSEMBLY OF THE PUMP UNIT

! These operations must be carried out by qualified technical personnel.

! Any work must be carried out when the pump is not operating. If a switch has been fitted, it must be set to the "off" position.

! Take precautions to ensure that the pump is not started involuntarily, disconnecting the cables from the power supply.

NOTE: Considerable precision and care must be taken when performing the operations involved in the assembly procedure.

NOTE: Thoroughly clean any parts still in good condition using water or an appropriate solvent before assembling a pump in repair.

NOTE: The assembly procedure should be carried out in a place free of dust and vibrations.

The tightening torques (N/m) for the pump assemblies are indicated here below:

Threading	Cast iron	Ductile iron	SS 304/316
	Nm	Nm	Nm
M6	4	4	4
M8	6	8	7
M10	10	12	10
M12	14	17	15
M14	19	24	20
M16	26	32	27
M20	40	49	42
M22	49	61	51
M24	57	71	60
M27	74	92	78
M30	90	112	95

TABLE 6.15.1: Tightening torques in N/m.

IEC motor frame	Torque (N/m)	Motor frame	Torque (N/m)
80 - 90	6	200 - 225	26
100 - 132	10	250 - 280	40
160 - 180	14	315	57

TABLE 6.15.2: Tightening torques for cast iron motor in N/m.

NOTE: Apply an equal torque to each bolt tightening in diagonal order.

ASSEMBLY PROCEDURE

 All steps of the assembly procedure must be performed to make the pump unit complies with 2006/42/EC Machinery Directive.

NOTE: Identify all of the parts and their codes on pages 32 to 43 before proceeding with assembly.

 **CAUTION** Damaged or deteriorated tools are dangerous. Use qualified and suitable tools only

The tools required for the assembly procedure are the follow:

- A. Straight-nose pliers for external elastic ring
- B. Straight-nose pliers for internal elastic ring
- C. Key for internal hexagon socket screws
- D. Curved-nose pliers for internal elastic ring
- E. Straight-nose pliers for internal elastic ring
- F. Hexagon key
- G. T-handle key for external hexagon socket screws
- H. Dynamometric wrench
- I. Belt wrench



STEP 1 (Assembly of bearing housing)

1. Lay all of the parts on the bench:
 - Bearing housing (Pos. 001)
 - Rear cover (Pos. 002)
 - Shaft (Pos. 009)
 - Radial ball bearing (Pos. 010, 112)
 - Housing cover (Pos. 011, 113)
 - Support foot (Pos. 012)
 - Seal ring (Pos. 020, 114)
 - Elastic ring (Pos. 021, 116)
 - O-ring (Pos. 024, 115)
 - Screw (Pos. 028) number of parts: 4-12.
 - Screw (Pos. 031) and washer (Pos. 022): number of parts: 2
 - Screw (Pos. 032) and washer (Pos. 078): number of parts: 4
 - Oil drainage plug (Pos. 038)
 - Oil filling plug (Pos. 039)
 - Oil level plug (pos. 071)



2. Insert the two seal rings (Pos. 020, 114) and the O-rings (Pos. 024, 115) into the relative housing covers (Pos. 011, 113), front and rear. Use a press to perform this operation to ensure that the seal ring is pressed into the cover as far as it will go.
3. Insert the two snap rings (Pos. 021, 116) into their locations in the housing (Pos. 001) using the curved-nose pliers for internal elastic ring (D) and straight-nosed pliers for internal elastic ring (E).



4. Insert the front bearing (Pos. 112), on the impeller side, into the housing on the shaft (Pos. 009).
5. Insert the shaft (Pos. 009) into the housing (Pos. 001), pressing evenly on the external and internal crown of the bearing (Pos. 112).
6. Insert the second bearing (Pos. 010), on the motor side, on the shaft (Pos. 009) already inserted in the housing, pressing evenly on the external and internal crown of the bearing (Pos. 010).
7. Place the housing covers (Pos. 011, 113) into their respective positions and tighten the screws (Pos. 028).
8. Position the support foot (Pos. 012) of the bearing housing (Pos. 001) and tighten the screws (Pos. 031, 022).
9. Place the cover (Pos. 002) into its respective position connected to the bearing housing (Pos. 001) and tighten the screws (Pos. 032, 078).



10. Screw the oil drainage plug (Pos. 038), oil filling plug (Pos. 039) and oil level plug (Pos. 071) into place.

STEP 2 (Assembly of mechanical seal)

NOTE: The follow assembly procedure is only valid for the JRS and JRS1 mechanical seals.

NOTE: Working lengths are provided on pages from 37 to 41.

1. Place all of the parts on the bench.
 - Stuffing box (Pos. 007)
 - Cylindrical pins (Pos. 014)
 - Shaft sleeve (Pos. 016)
 - Spray guard (Pos. 041)
 - O-ring (Pos. 042)
 - Seal chamber (Pos. 047)
 - O-ring (Pos. 048)
 - O-ring (Pos. 049)
 - Rotating part of the mechanical seal (Pos. 053).
 - Static ring of the mechanical seal (Pos. 053a).
 - Mechanical seal gasket (Pos. 053b).
 - Screw (Pos. 055)

- Retaining flange (Pos. 056)
- Spacer (Pos. 060)
- Key (Pos. 069)

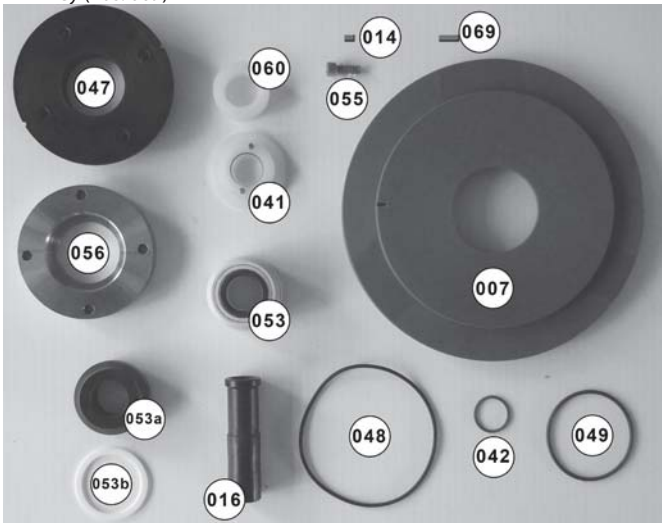

2. Insert the static ring of the mechanical seal (Pos. 053a) and its gaskets (Pos. 053b) into the stuffing box (Pos. 047) in such a way that the lapped part will be against the rotating ring of the seal in step 14.
3. Fit the retaining flange (Pos. 056) on to the seal chamber (Pos. 047) and tighten the screws (Pos. 055) using a dynamometric wrench (H), making sure that it is tightened to the right torque value (7 Nm).



4. Fit the O-rings (Pos. 048, 049) in to their respective positions in the stuffing box (Pos. 007).

5. Place the seal chamber (Pos. 047) in to the stuffing box (Pos. 007), matching up the internal flushing holes. The pins inserted previously into the stuffing box (Pos. 007) help to ensure it is centred properly.



6. Insert the rotating part of the seal (Pos. 053) in to the shaft sleeve (Pos. 016).
7. Insert the spacer (Pos. 060) against the rear part of the rotating mechanical seal (Pos. 053).

8. Insert the O-ring (Pos. 042) and cylindrical pins (Pos. 014) in to their respective positions inside the shield (pos. 041).
9. Hook the spray guard (Pos. 041) on to the spacer (Pos. 060) using the relevant pins (Pos. 014); this will create a single unit composed of the shaft sleeve (Pos. 016), rotating part of the mechanical seal (Pos. 053), spacer (Pos. 060) and spray guard (Pos. 041).

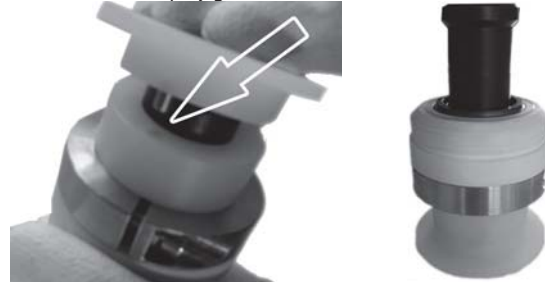

10. Insert the protection (Pos. 111) into the relevant joint on the housing cover (Pos. 011) with the drainage holes facing downwards.

11. Insert the seal unit until it abuts with the shaft (Pos. 009).



12. Lock the shaft sleeve into position using the key (Pos. 069).

13. Evenly screw the fixing screws for the seal (Pos. 053) using the key for internal hexagon socket screws (C).



14. Assemble the stuffing box (Pos. 007) on to the rest of the pump so that the internal flushing hole points upwards.



STEP 3 (Casing assembly)

1. Place all of the parts on the bench.

- Stud bolts (pos. 013)
- Impeller nozzle (Pos. 017)
- Key (Pos. 019)
- O-ring (Pos. 025)
- Cap (Pos. 026)
- O-ring (Pos. 027)
- Self-locking nut (Pos. 033 - for housing 1) or half nut (Pos. 033 - for housings 2, 3 and 4)
- Nut (Pos. 034)
- Impeller washer (Pos. 036)
- Washer (Pos. 037)
- O-ring (Pos. 044)
- Suction nozzle (Pos. 045)
- O-ring (Pos. 046)
- Snap ring (pos. 83)



2. Tighten the number of stud bolts (Pos. 013) consonant with the metal armour (Pos. 003).

3. Insert the suction nozzle (Pos. 045) inside the pump's metal armour (Pos. 003).



4. Lock the suction nozzle (Pos. 045) into its housing with the snap ring (Pos. 021) using a pair of straight-nose pliers for external ring (A).



5. Position the internal O-ring (Pos. 044) on to the lower part of the suction nozzle (Pos. 045).



6. Insert the key (Pos. 019) inside the front housing of the shaft (Pos. 009), on the impeller side, to lock the shaft sleeve into place (Pos. 016).

7. Insert the cap (Pos. 026) into its housing on the rear part of the impeller (Pos. 008).



8. Insert the impeller (Pos. 008) so that the upper part of the key (Pos. 019) slides in the housing of the impeller (Pos. 008).

9. Fasten the self-locking nut or 2 half-nuts (Pos. 033) and impeller washer (Pos. 036) to the shaft (Pos. 009) using a T-handled key for external hexagon socket screws (G) and a belt wrench (I) to hold the impeller (Pos. 008) in place.



10. Insert the O-ring (Pos. 027) onto the impeller nozzle (Pos. 017).

11. Screw (right-handed thread) the hub (Pos. 017) onto the impeller (Pos. 008).

12. Tighten the impeller nozzle (Pos. 017) using straight-nose pliers for internal elastic ring (E).



13. Place the O-ring (Pos. 025) into its respective housing on the cover (Pos. 007).

14. Insert the pump casing (Pos. 006) so that it slots into place on the stuffing box (Pos. 007).



15. Position the metal armour (Pos. 003) so that all of the stud bolts (Pos. 013) enter the respective housings in the rear cover (Pos. 002).



16. Put the washers (Pos. 037) into place and provisionally tighten the bolts (Pos. 034) using a spanner.



17. Check that the casing is level with the metal armour using a depth gauge.



18. Place all of the parts on the bench.

- Discharge flange (Pos. 004)
- Discharge nozzle (Pos. 015)
- Key (Pos. 018)
- Screw (Pos. 030)
- O-ring (Pos. 043)



19. Insert the O-ring (Pos. 043) into the lower housing of the discharge nozzle (Pos. 015).

20. Position the discharge nozzle (Pos. 015) and lock it into place with the discharge flange (Pos. 004).



21. Fasten the discharge flange (Pos. 004) with the screws (Pos. 030) using a dynamometric wrench (see tightening torques table on 6.15.1).

22. Use a dynamometric wrench to fasten the closure bolts (see tightening torques table 6.15.1).



23. Tighten the discharge stud bolts (Pos. 035) and suction stud bolts (pos. 040).

! Do not tighten the studs over the extension of the thread of the pump. Always check the depth of the tapped holes before tightening the studs.

STEP 4 (Pump-baseplate assembly)

1. Lay all the parts on the bench:

- Flexible coupling parts Pos. 82, (A, B, C, D).
- Rubber coupling plugs (Pos. 84)
- Screws (Pos. 85), washers (Pos. 88), grub screws



2. Position the motor (Pos. 065), adjust its position by the spacing screws (Pos. 103) and lightly tighten the fixing screws (Pos. 080, 081).

3. Position the pump and lightly tighten the fixing screws (Pos. 063, 073, 074, 075) of the metal armour (Pos. 003) and frame's leg (Pos. 012).

4. Check the distance between the two shafts (see "Y" value on page 46).



5. Insert Part A (Pos. 082) of the coupling onto the pump shaft (Pos. 009) until the mark on the pump shaft.

6. Tighten the cylindrical head screws inside Pos. 082 of the coupling.

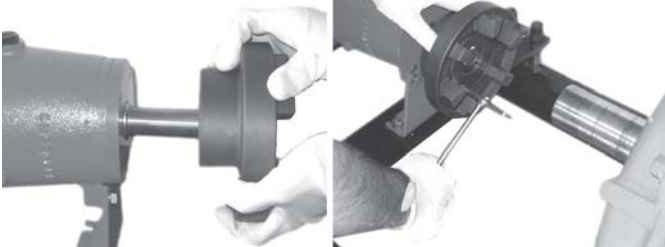

7. Insert the rubber plugs (Pos. 084) onto the coupling (Pos. 082A).

8. Position part D of the coupling onto the shaft of the motor until to reach the same axis of the end of the shaft and tighten the screws (Pos. 083, 088).

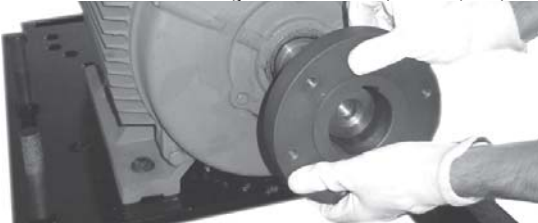

9. Insert part B of the coupling onto the part A.



10. Insert part C of the coupling between the part B and D.



11. Tighten the fixing screws (Pos. 083, 088) between the part C and the other components of the coupling (part A, B and D).



12. Align the pump unit (see paragraph 4.3).

13. Tighten the screws on the baseplate (Pos. 063, 073, 074, 075, 076, 077).

14. Check the alignment (see the "Y" value given in the table on page 46) and repeat operations 12 and 13 if the alignment does not fall within the established tolerances.

15. Position the coupling guard (Pos. 070) and fasten with the screws (Pos. 080, 081, 094, 096, 106).



Before to put again in operation the pump unit verify that all parts have been assembled according to 2006/42/EC Machinery Directive. A technical assessment of the conformity of the pump unit assembled by the user can be requested to the manufacturer.



Before the start-up review all of the points listed in paragraph 5.5.

6.16 PUMP-MOTOR AXIS ALIGNMENT

The CGD and CGD-E baseplates have a pump-motor axis alignment and adjustment system.

The procedure for aligning the motor is as follows:

1. Screw the nuts (Pos. 097, 098, 099) onto the bolts of the base (Pos. 103).
2. Position the motor support base (Pos. 095).
3. Position the motor (Pos. 065) onto the support base (Pos. 095) and tighten the fixing screws (Pos. 076, 077).
4. Adjust the motor axis to the required dimension by screwing or unscrewing the nuts in a crosswise fashion (Pos. 099).
5. Align the coupling following the instructions given in Paragraph 5.3.
6. If the measurements fall within the tolerances given in Tables 5.3.3 and 5.3.4, proceed with tightening the fixing nuts (Pos. 098, 104).

6.17 CAUSES OF TROUBLE AND TROUBLESHOOTING

TROUBLE	CAUSES	TROUBLESHOOTING
THE PUMP DOES NOT PUMPING OR IN SUCTION CONDITIONS THE PRIMING IS SLOW	Insufficient NPSHa	Check NSPHa is greater then NSPHr + 1 meter.
	The end of the suction pipe or the foot valve are not submerged.	Submerge the end of the pipe or the foot valve at the recommended distance.
	In the suction condition the foot valve is too small or faulty	Check or replace the foot valve.
	In the suction condition the suction lift exceed the pump ability.	Check the suction height is not higher than the pump limit or the level of liquid is the tank is not too low.
	The suction pipe is too long or the diameter is too small.	Check the dimension of the suction pipe.
	Air leaks in the suction piping.	Check the sealing condition and tightening between the connections on the suction piping.
	The gate valve in the suction pipe is closed or partially closed.	Open the gate valve completely.
	The specific gravity, temperature or viscosity of the liquid are higher then design values.	Check the specific gravity, temperature and viscosity values.
	Foreign bodies obstruct the impeller or the suction or discharge piping.	Remove the foreign bodies.
	The impeller is worn or damaged or the distance between the impeller and the casing is greater than recommended.	Replace the impeller.
	The discharge valve is closed.	Open the discharge valve.
	Two-phase motor operation.	Check the motor's electrical power supply.
	The speed of rotation is low.	Check the wiring.
	The sense of rotation is wrong.	Check the wiring.
The frequency is not suitable for the pump.	Check the frequency.	
INSUFFICIENT FLOW OR PRESSURE	Air pockets are in the piping.	Check the piping conditions.
	The liquid contains air or gas.	Check the liquid conditions.
	Foreign bodies obstruct the impeller or the suction or discharge piping.	Remove the foreign bodies.
	The impeller is worn or damaged or the distance between the impeller and the casing is greater than recommended.	Replace the impeller.
	Total head of the plant greater then the head provided by the pump.	Check hydraulic losses and condition of the plant.
	The viscosity of the liquid is higher then design values.	Check the specific gravity, temperature and viscosity values.
	The speed of rotation is low.	Check the wiring.
	The sense of rotation is wrong.	Check the wiring.
PUMP VIBRATES EXCESSIVELY	The frequency is not suitable for the pump.	Check the frequency.
	The pump cavitating.	Check the plant conditions and the causes of the cavitation.
	Duty point outside the recommended flow rate.	Regulate the duty point according the recommended flow rate.
	Foreign bodies obstruct the impeller or the suction or discharge piping.	Remove the foreign bodies.
	One or some parts of the pump are damaged or worn.	Disassembly the pump and replace the damaged or worn parts.
	The pump or motor bearings are worn.	Replace the motor bearing.
	The baseplate is not anchored firmly.	Anchor the baseplate firmly to a reinforced concrete base.
	The installation screws are not tightened.	Tighten the bolts.
THE MOTOR IS OVERHEATED	Wear of the elastic part of the coupling.	Replace the elastic part of the coupling.
	Incorrect pump unit alignment.	Check the alignment of the pump.
	The discharge valve is too open.	Regulate the discharge valve according the declared duty point.
	The specific gravity or viscosity of the liquid are higher then design values.	Check the specific gravity and viscosity values.
	The ambient temperature is too high.	Install the motor providing a minimum distance from other objects and supplying a proper ventilation.
	The speed of rotation is high.	Check the wiring.
	Excessive compression of the elastic element on the mechanical sealing	Contact the manufacturer.
RAPID WEAR OF MECHANICAL SEAL	The bearings of the housing or motor are defective.	Replace the bearings of the pump or the motor.
	Pump and motor are not aligned correctly.	Realign the pump unit.
	The flushing or pumped liquid contains foreign bodies or abrasive substances.	Check that the percentage of solid particles does not exceed the maximum amount allowed for the application.
	The materials of the mechanical seal are not compatible with the liquid.	Contact the manufacturer.
	The pumped liquid causes the formation of air or gas.	Contact the manufacturer.
	Duty point outside the recommended flow rate.	Regulate the duty point according the recommended flow rate.
RAPID WEAR OF BEARINGS	Dry run operation.	Check the installation and operation of the pump.
	The pump and motor are not aligned correctly.	Realign the pump unit.
	Duty point outside the recommended flow rate.	Regulate the duty point according the recommended flow rate.
	No lubricant in the housing.	Lubricate the housing.
	Presence of foreign bodies in the lubricant.	Make sure the lubricant is clean.
	Presence of water or condensate in the housing or motor.	Contact the manufacturer.
	Excessive thrust on the bearings caused by mechanical defects.	Contact the manufacturer.
MECHANICAL FAULTS OR DAMAGE TO THE PUMP	Mechanical faults or damage to the pump.	Contact the manufacturer.
	The pump and motor are not aligned correctly.	Realign the pump unit.

NOTE: Contact the manufacturer in case the failure reason has not been found.

7.0 COMPONENTS LIST

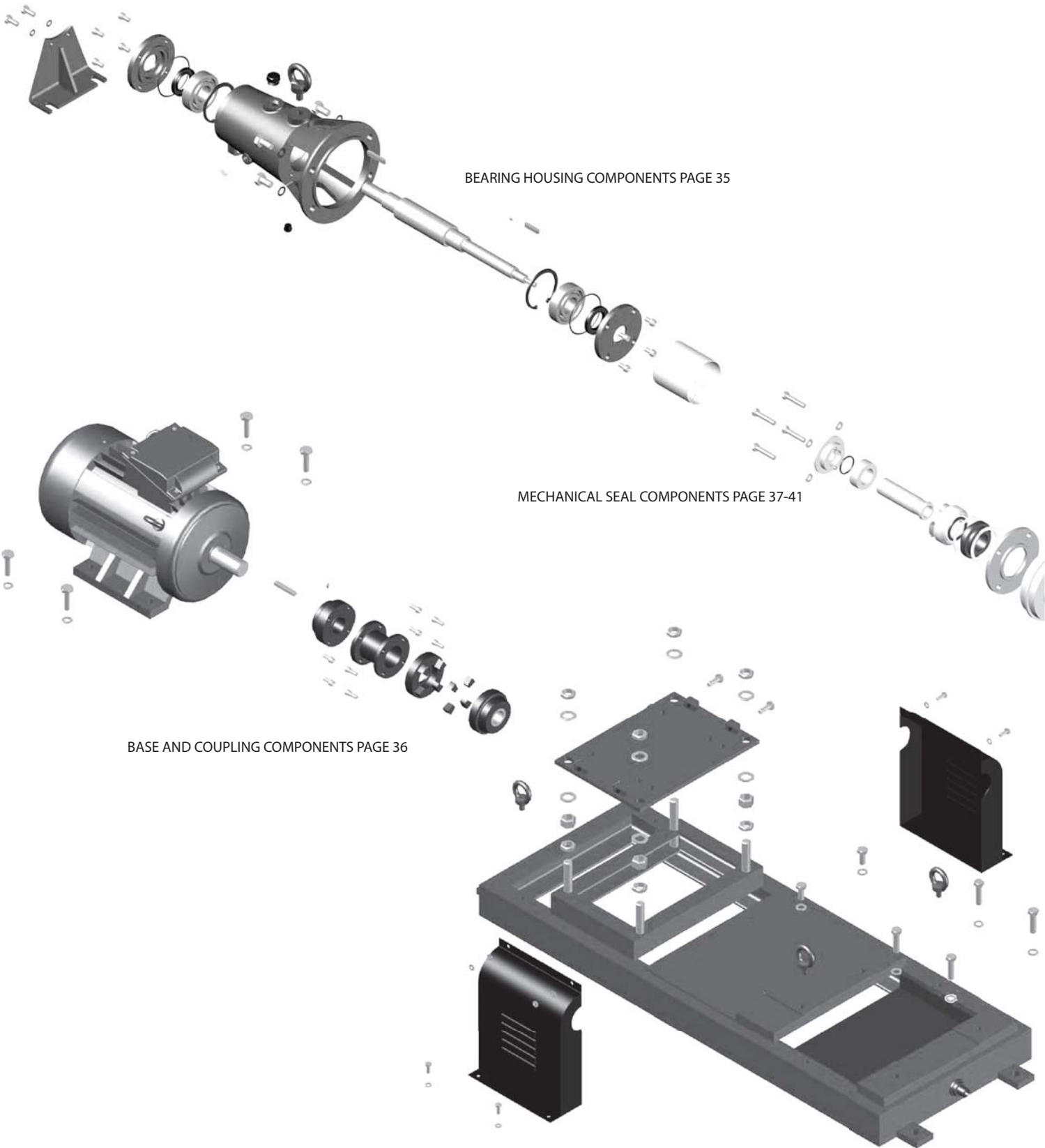

BEARING HOUSING COMPONENTS PAGE 35

MECHANICAL SEAL COMPONENTS PAGE 37-41

BASE AND COUPLING COMPONENTS PAGE 36

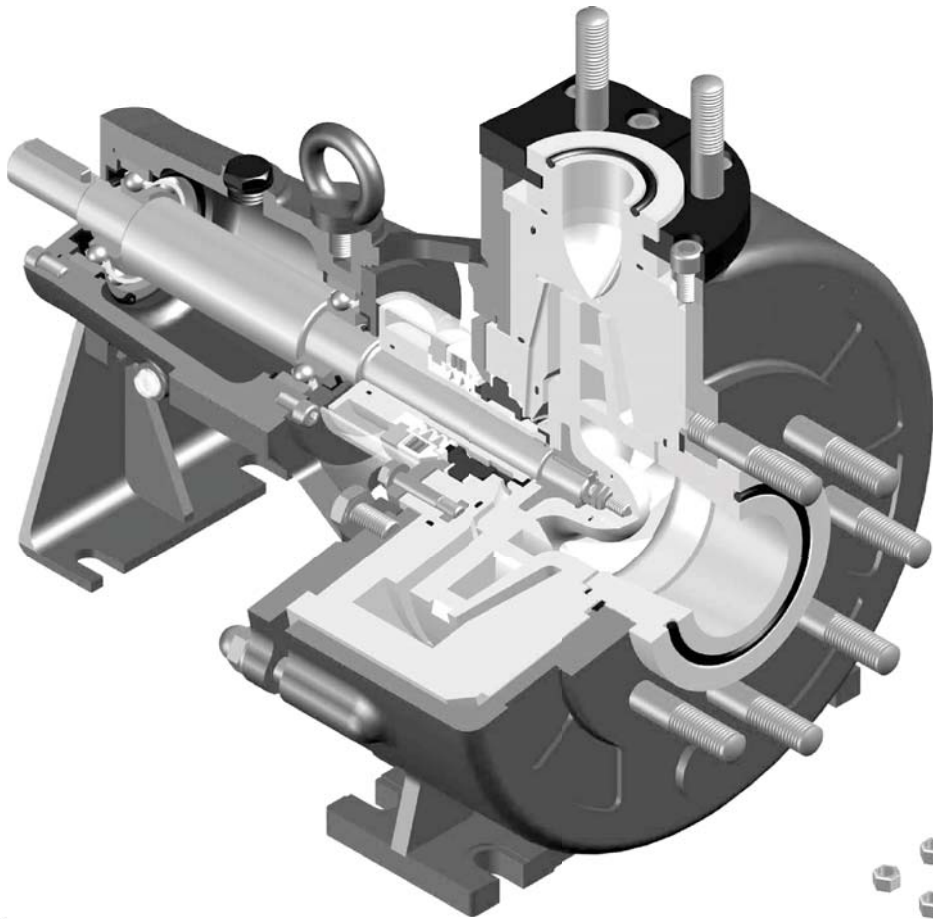

CASING COMPONENTS PAGE 34

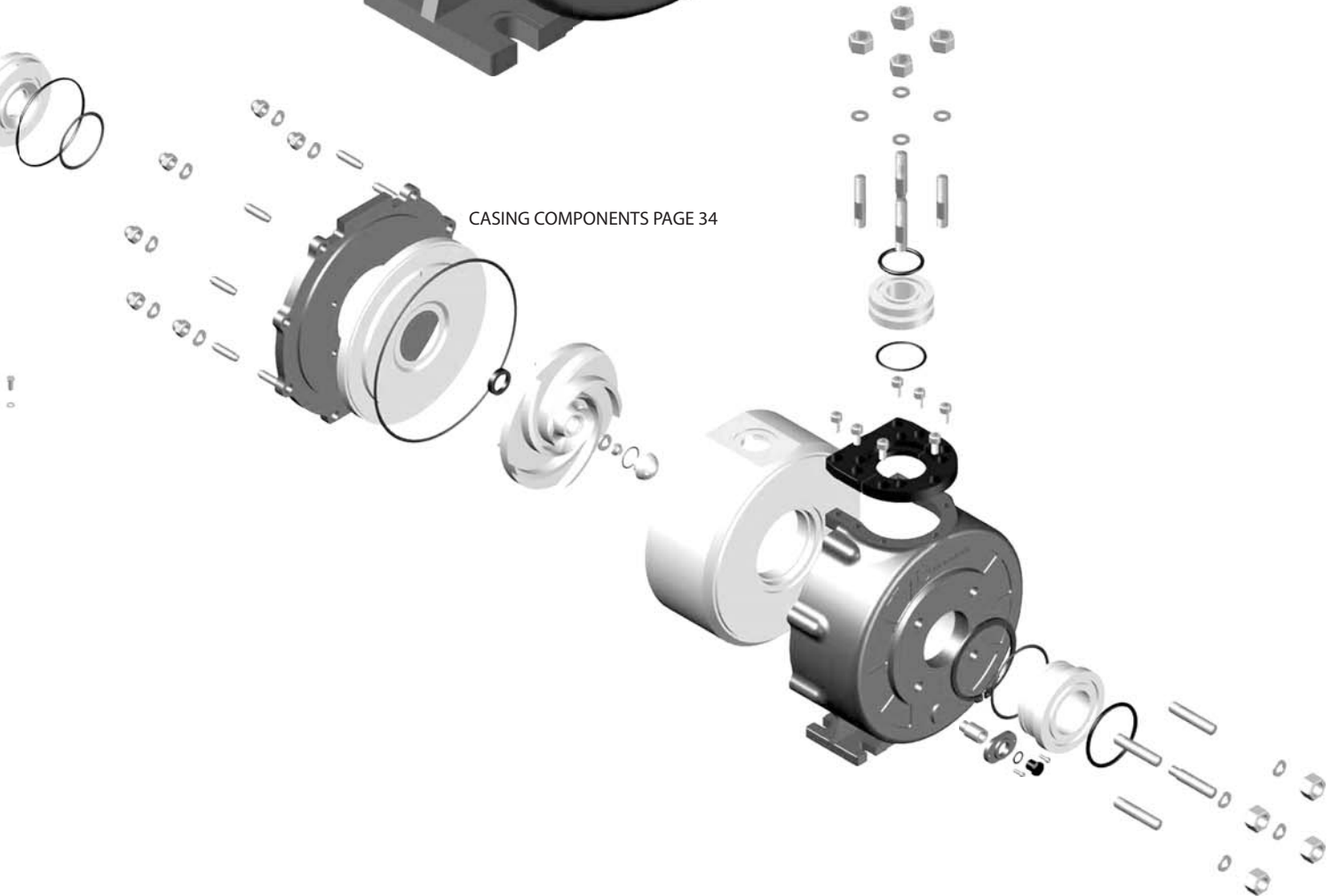

7.1 PUMP CASING

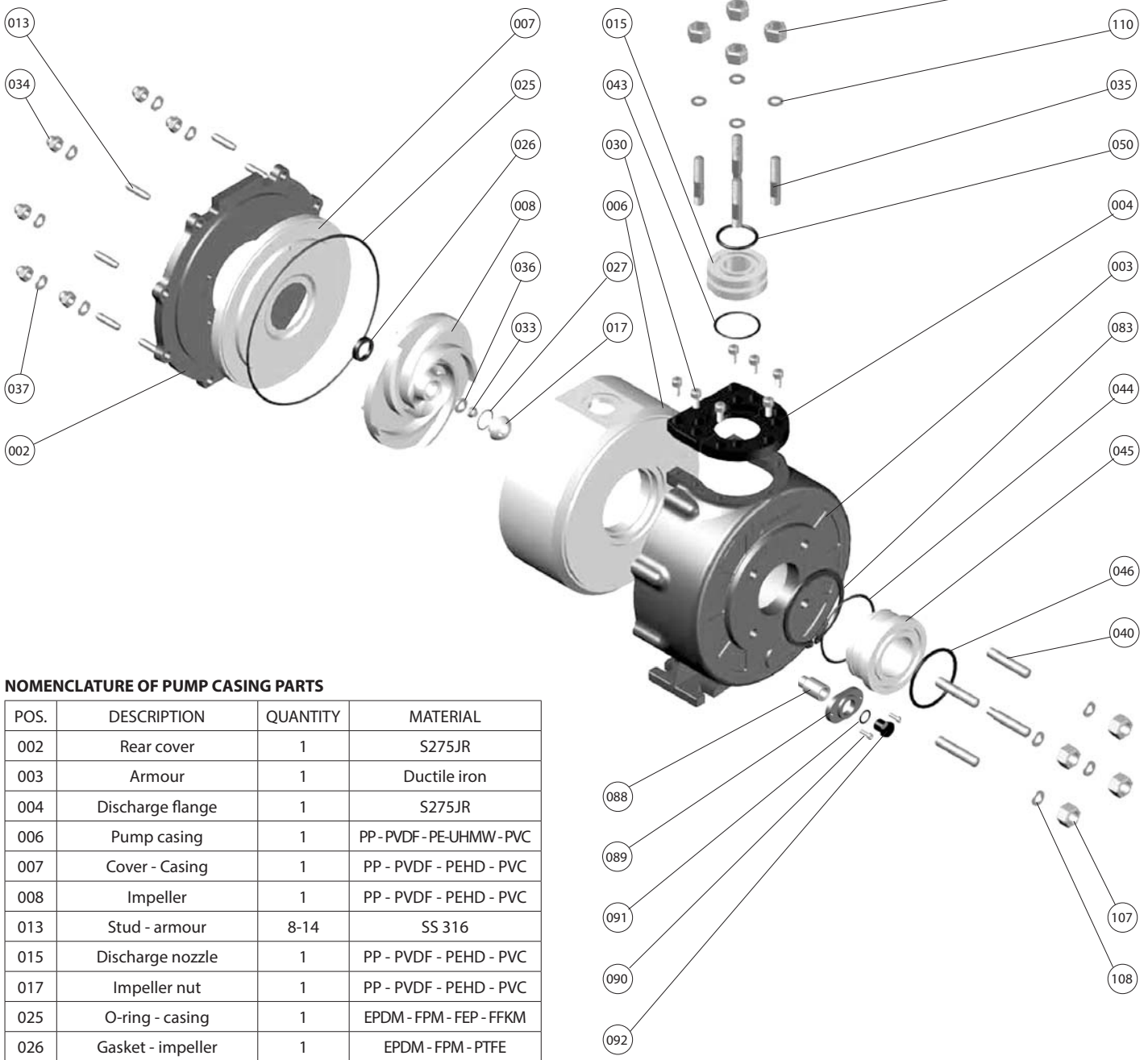

NOMENCLATURE OF PUMP CASING PARTS

POS.	DESCRIPTION	QUANTITY	MATERIAL
002	Rear cover	1	S275JR
003	Armour	1	Ductile iron
004	Discharge flange	1	S275JR
006	Pump casing	1	PP - PVDF - PE-UHMW - PVC
007	Cover - Casing	1	PP - PVDF - PEHD - PVC
008	Impeller	1	PP - PVDF - PEHD - PVC
013	Stud - armour	8-14	SS 316
015	Discharge nozzle	1	PP - PVDF - PEHD - PVC
017	Impeller nut	1	PP - PVDF - PEHD - PVC
025	O-ring - casing	1	EPDM - FPM - FEP - FFKM
026	Gasket - impeller	1	EPDM - FPM - PTFE
027	O-ring - Impeller nose	1	EPDM - FPM - FEP - FFKM
030	Hexagon head screw	7	SS 316
033	Locknut - impeller	1	SS 316
034	Nut - armour	8-14	SS 316
035	Stud - discharge flange	4-12	SS 316
036	Washer - impeller	1	42CrMo4
037	Washer - armour	8-14	SS 316
040	Stud - suction flange	4-12	SS 316
043	O-ring - discharge flange	1	EPDM - FPM - FEP - FFKM
044	O-ring - suction flange	1	EPDM - FPM - FEP - FFKM
045	Suction nozzle	1	PP - PVDF - PEHD - PVC
046	O-ring - suction flange	1	EPDM - FPM - FEP - FFKM
050	O-ring - discharge flange	1	EPDM - FPM - FEP - FFKM

POS.	DESCRIPTION	QUANTITY	MATERIAL
083	Snap ring - suction flange	1	55Si7
088	Drainage	1	PP - PVDF - PEHD - PVC
089	Cover - drainage	1	S275JR
090	Screw - drainage	2	SS 316
091	O-ring - drain plug	1	EPDM - FPM - FEP - FFKM
092	Drain plug	1	PP - PVDF - PEHD - PVC
107	Nut - suction flange	4-12	SS 316
108	Washer - suction flange	4-12	SS 316
109	Nut - discharge flange	4-12	SS 316
110	Washer - discharge flange	4-12	SS 316

7.2 BEARING HOUSING

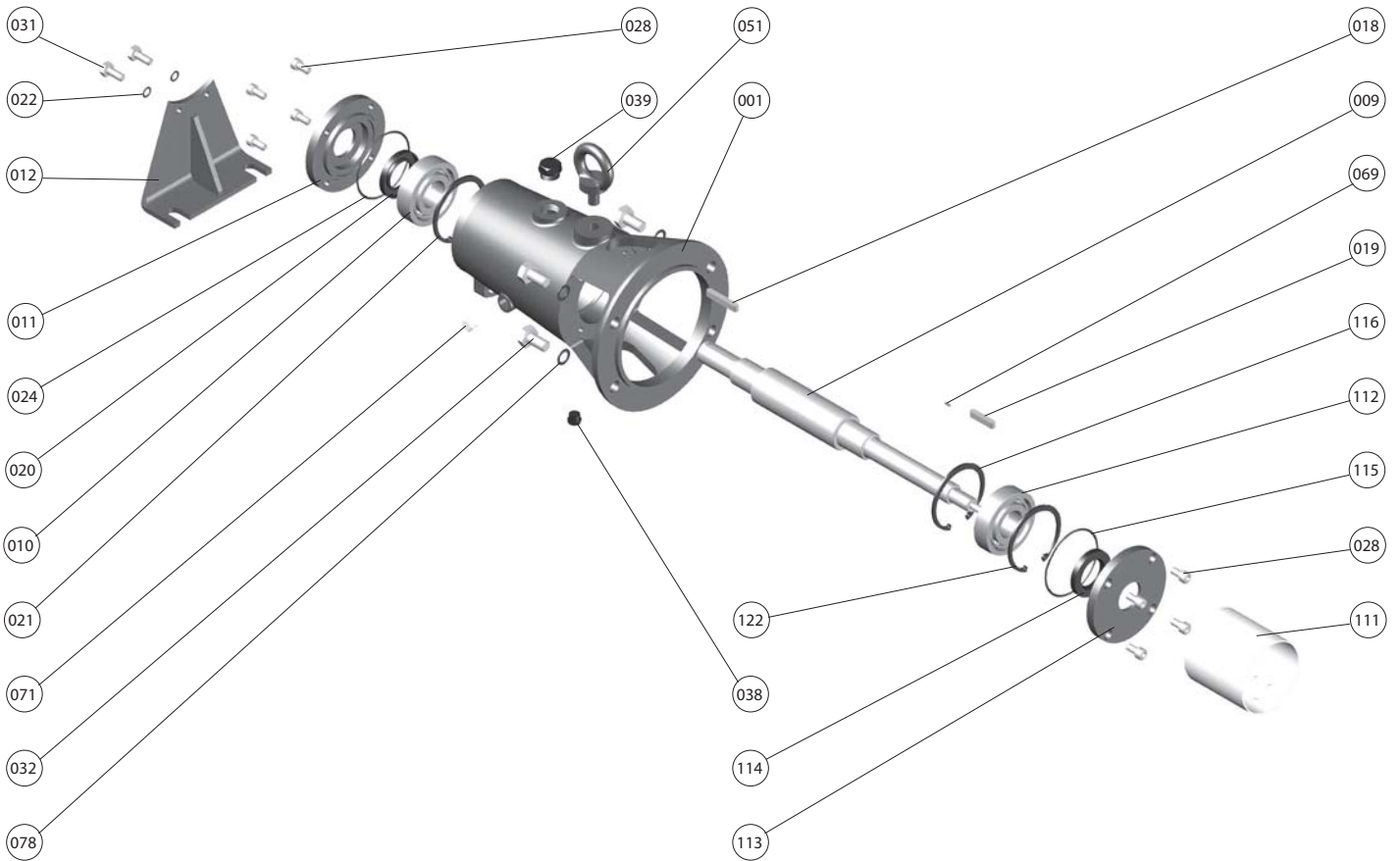

NOMENCLATURE OF BEARING HOUSING PARTS

POS.	DESCRIPTION	QUANTITY	MATERIAL
001	Bearing housing	1	Cast iron
009	Shaft	1	42CrMo4 - Super Duplex ⁽¹⁾
010	Radial ball bearing	1	-
011	Bearing cover	1	C45
012	Support foot	1	S275JR
018	Key - shaft (motor side)	1	C45 or SS 304 / 316 ⁽¹⁾
019	Key - shaft (impeller side)	1	C45 or SS 304 / 316 ⁽¹⁾
020	Seal ring	1	NBR
021	Snap ring	1	55Si7
022	Washer - support foot	2	SS 316
024	O-ring - bearing cover	1	NBR
028	Screw - bearing cover	8-12	SS 316
031	Screw - support foot	2	SS 316
032	Screw - bearing housing	4	SS 316
038	Oil drain plug	1	PA
039	Oil fill plug	1	PA
051	Eyebolt	1	Cast iron
069	Key - shaft sleeve	1	C45
071	Oil level plug	1	PA / PA-T-AR
078	Washer - bearing housing	4	SS 316
111	Protection	1	PMMA

POS.	DESCRIPTION	QUANTITY	MATERIAL
112	Radial ball bearing	1	Sales
113	Bearing cover	1	C45
114	Seal ring	1	NBR
115	O-ring - bearing cover	1	NBR
116	Snap ring ⁽³⁾	1	55Si7
122	Snap ring ⁽²⁾	1	55Si7

NOTES:

(1) Special execution on request.

(2) Only for model 100-250.

(3) Not for model 100-250.

7.3 BASE, DRIVE AND COUPLING

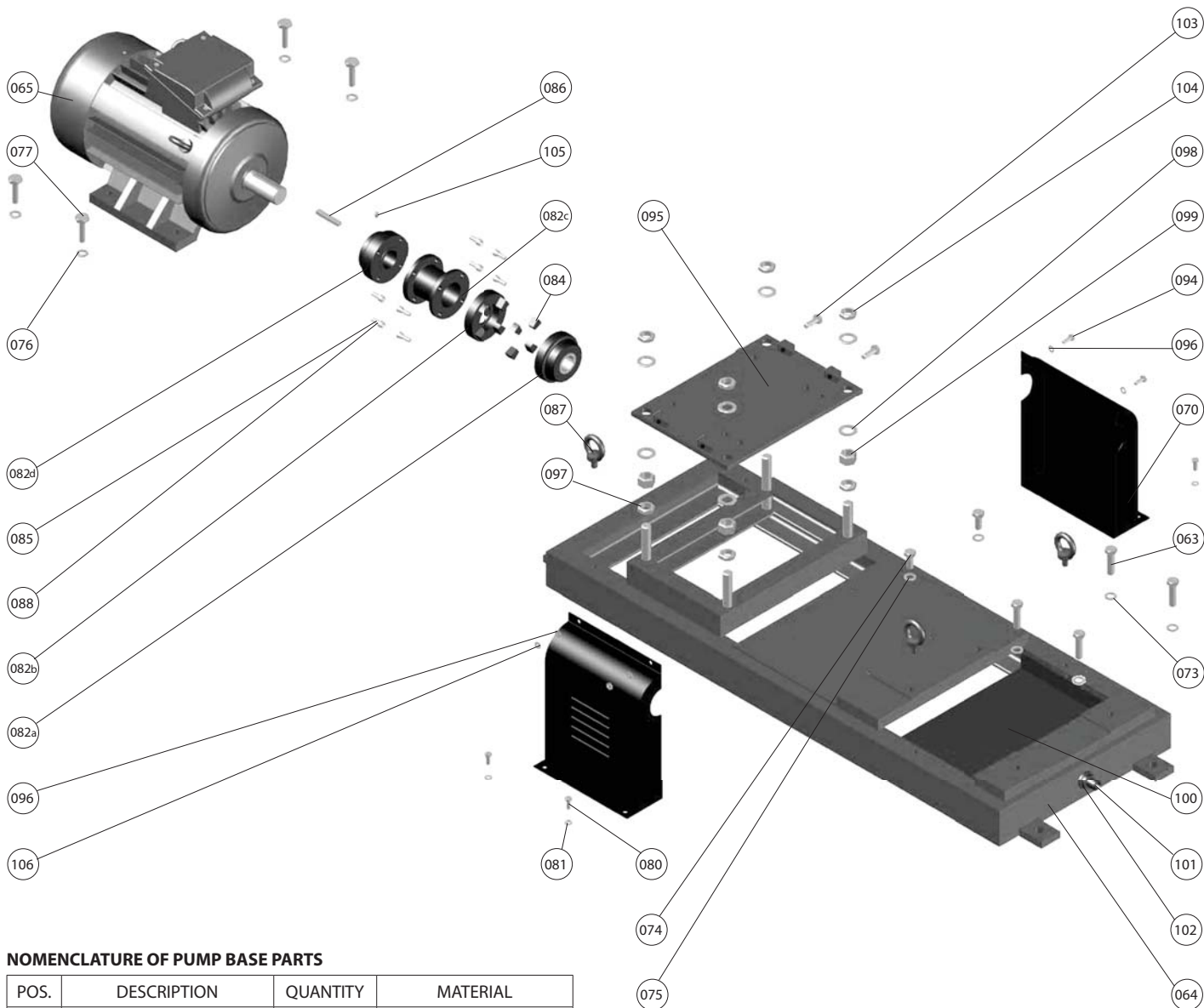

NOMENCLATURE OF PUMP BASE PARTS

POS.	DESCRIPTION	QUANTITY	MATERIAL
063	Screw - armour	4	SS 316
064	Base	1	S275JR
065	Motor	1	Aluminium or Cast iron
070	Coupling guard	1	S275JR
073	Washer - armour	4	SS 316
074	Screw - support foot	2	SS 316
075	Washer - support foot	2	SS 316
076	Washer - motor	4	SS 316
077	Screw - motor	4	SS 316
080	Screw - coupling guard	4	SS 316
081	Washer - coupling guard	4	SS 316
082	Coupling	1	Cast iron
084	Rubber element - coupling	4-8	NBR 75Sh
085	Screw - coupling	8-16	UNI 5931 (class 8.8)
086	Key - motor	1	C45 or SS 304 / 316 ⁽¹⁾
087	Eyebolt	4	Cast iron
088	Washer - coupling	8-16	UNI 5931 (class 8.8)

POS.	DESCRIPTION	QUANTITY	MATERIAL
094	Screw - coupling guard	2	SS 316
095	Base plate - motor	1	S275JR
096	Washer - coupling guard	4	SS 316
097	Slim nut - base plate	4	SS 316
098	Washer - base plate	8	SS 316
099	Nut - base plate	4	SS 316
100	Basin	1	PVC
101	Nozzle	1	PVC
102	Nut	1	PVC
103	Spacing screw ⁽²⁾ - base plate	4	SS 316
104	Slim nut - base plate	4	SS 316
105	Grub screw - coupling	1	SS 304
106	Nut - coupling guard	2	SS 316

NOTES:

- (1) Special execution on request.
- (2) Only from 160 motor frame.

7.4 JRS - JRS1 - JTP - JRA - JRG SEALS

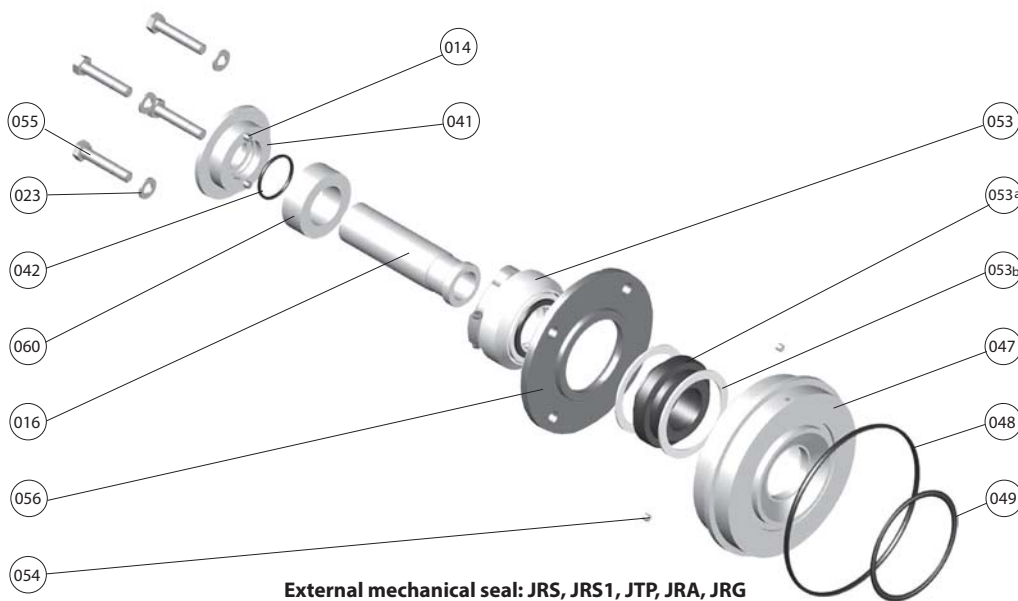

External mechanical seal: JRS, JRS1, JTP, JRA, JRG

Positioning of the mechanical seal

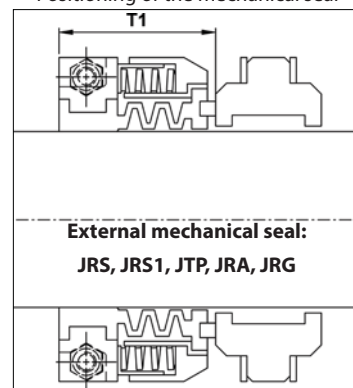

**External mechanical seal:
JRS, JRS1, JTP, JRA, JRG**

Seal's diameter	T1 (mm)
30	37
35	38
40 - 45	40
55 - 65 - 75	53

NOMENCLATURE OF MECHANICAL SEAL PARTS

POS.	DESCRIPTION	QUANTITY	MATERIAL
014	Cylindrical pin	2	SS 304
016	Shaft sleeve	1	PP - PVDF - PE-UHMW - PVC
023	Washer - seal chamber	4	SS 316
041	Spray guard	1	PP
042	O-ring - spray guard	1	EPDM - FPM - PFA - FFKM
047	Seal chamber	1	PP - PVDF - PE-HD - PVC
048	O-ring - seal chamber	1	EPDM - FPM - FFKM
049	O-ring - seal chamber	1	EPDM - FPM - FFKM
053	Mechanical seal JRS (rotating ring)	1	SS 316 - PTFE C - SiC
	Mechanical seal JRS1 (rotating ring)	1	SS 316 - PTFE C - SiC
	Mechanical seal JTP (rotating ring)	1	SS 316 - PTFE C - PTFE C
	Mechanical seal JRA (rotating ring)	1	SS 316 - PTFE C - SiC
	Mechanical seal JRG (rotating ring)	1	SS 316 - PTFE C - Carbographe
053a	Mechanical seal JRS (static ring)	1	SiC
	Mechanical seal JRS1 (static ring)	1	SiC
	Mechanical seal JTP (static ring)	1	Al ₂ O ₃
	Mechanical seal JRA (static ring)	1	Al ₂ O ₃
	Mechanical seal JRG (static ring)	1	Al ₂ O ₃
053b	Gasket - static ring	2	PTFE
054	Cylindrical pin - seal chamber	2	SS 304
055	Screw - seal chamber	4	SS 316
056	Cover - seal chamber	1	SS 316
060	Spacer	1	PP

JRS MECHANICAL SEAL TECHNICAL DATA

Seal diameter (mm)	Temperature range (°C)	Max. pressure (Bar g)	Max. RPM
30 - 35 - 40	-45 / +90	8	3500
45 - 55			
65 - 75		7	

APPLICABLE API PLANS: 01 - 11 - 12 - 32

JRS1 MECHANICAL SEAL TECHNICAL DATA

Seal diameter (mm)	Temperature range (°C)	Max. pressure (Bar g)	Max. RPM
30 - 35 - 40	-30 / +90	7	3500
45 - 55			
65 - 75		5	

APPLICABLE API PLANS: 01 - 11 - 12 - 32

JTP MECHANICAL SEAL TECHNICAL DATA

Seal diameter (mm)	Temperature range (°C)	Max. pressure (Bar g)	Max. RPM
30 - 35 - 40	-45 / +95	8	3500
45 - 55			
65 - 75		7	

APPLICABLE API PLANS: 01 - 11 - 12 - 32

JRA - JRG MECHANICAL SEAL TECHNICAL DATA

Seal diameter (mm)	Temperature range (°C)	Max. pressure (Bar g)	Max. RPM
30 - 35 - 40	-45 / +90	8	3500
45 - 55			
65 - 75		7	

APPLICABLE API PLANS: 01 - 11 - 12 - 32

7.5 JR2S - JR2S1 - JT2P - JR2A - JR2G SEALS

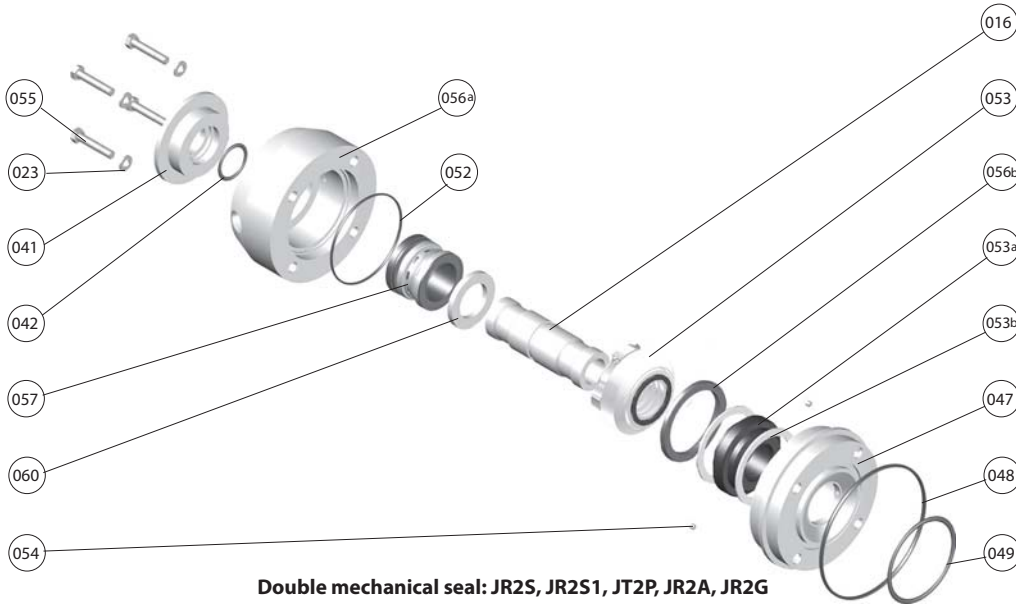

Double mechanical seal: JR2S, JR2S1, JT2P, JR2A, JR2G

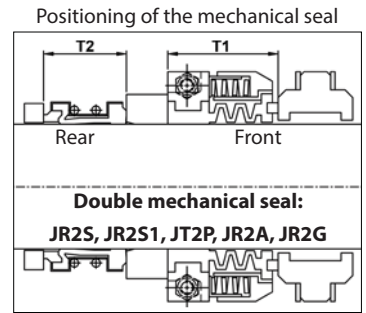

Seal's diameter	T1 (mm)
30	37
35	38
40 - 45	40
55 - 65 - 75	53

Seal's diameter	T2 (mm)
30 - 35	26
40 - 45 - 55	30
65	33
75	40

NOMENCLATURE OF MECHANICAL SEAL PARTS

POS.	DESCRIPTION	QUANTITY	MATERIAL
016	Shaft sleeve	1	PP - PVDF - PE-UHMW - PVC
023	Washer - seal chamber	4	SS 316
041	Spray guard	1	PP
042	O-ring - spray guard	1	EPDM - FPM - PFA - FFKM
047	Seal chamber	1	PP - PVDF - PEHD - PVC
048	O-ring - seal chamber	1	EPDM - FPM - FFKM
049	O-ring - seal chamber	1	EPDM - FPM - FFKM
052	O-ring - external chamber	1	EPDM - FPM - FFKM
053	Mechanical seal JR2S (rotating ring)	1	SS 316 - PTFE C - SiC
	Mechanical seal JR2S1 (rotating ring)	1	SS 316 - PTFE C - SiC
	Mechanical seal J2TP (rotating ring)	1	SS 316 - PTFE C - PTFE C
	Mechanical seal J2RA (rotating ring)	1	SS 316 - PTFE C - SiC
	Mechanical seal J2RG (rotating ring)	1	SS 316 - PTFE C - Carbographite
053a	Mechanical seal J2RS (static ring)	1	SiC
	Mechanical seal J2RS1 (static ring)	1	SiC
	Mechanical seal J2TP (static ring)	1	Al ₂ O ₃
	Mechanical seal J2RA (static ring)	1	Al ₂ O ₃
	Mechanical seal J2RG (static ring)	1	Al ₂ O ₃
053b	Gasket - static ring	2	PTFE
054	Cylindrical pin - seal chamber	2	SS 304
055	Screw - seal chamber	4	SS 316
056a	External seal chamber	1	PP
056b	Ring - seal chamber	1	SS 316
057	Mechanical seal	1	SS 316 - SiC - SiC
060	Spacer	1	PP

JR2S MECHANICAL SEAL TECHNICAL DATA

Seal diameter (mm)	Temperature range (°C)	Max. pressure (Bar g)	Max. RPM
30 - 35 - 40	-45 / +90	8	3500
45 - 55		7	1780
65 - 75		7	1780

APPLICABLE API PLANS: 01 - 11 - 12 - 32 + 52 - 53 - 54

JR2S1 MECHANICAL SEAL TECHNICAL DATA

Seal diameter (mm)	Temperature range (°C)	Max. pressure (Bar g)	Max. RPM
30 - 35 - 40	-30 / +90	7	3500
45 - 55		6	
65 - 75		5	1780

APPLICABLE API PLANS: 01 - 11 - 12 - 32 + 52 - 53 - 54

JT2P MECHANICAL SEAL TECHNICAL DATA

Seal diameter (mm)	Temperature range (°C)	Max. pressure (Bar g)	Max. RPM
30 - 35 - 40	-45 / +95	8	3500
45 - 55		7	1780
65 - 75		7	1780

APPLICABLE API PLANS: 01 - 11 - 12 - 32 + 52 - 53 - 54

JR2A - JR2G MECHANICAL SEAL TECHNICAL DATA

Seal diameter (mm)	Temperature range (°C)	Max. pressure (Bar g)	Max. RPM
30 - 35 - 40	-45 / +90	8	3500
45 - 55		7	1780
65 - 75		7	1780

APPLICABLE API PLANS: 01 - 11 - 12 - 32 + 52 - 53 - 54

7.6 B6EDF - B6EDFC - B6E - B6EC - B6EFL - B6EFLC SEALS

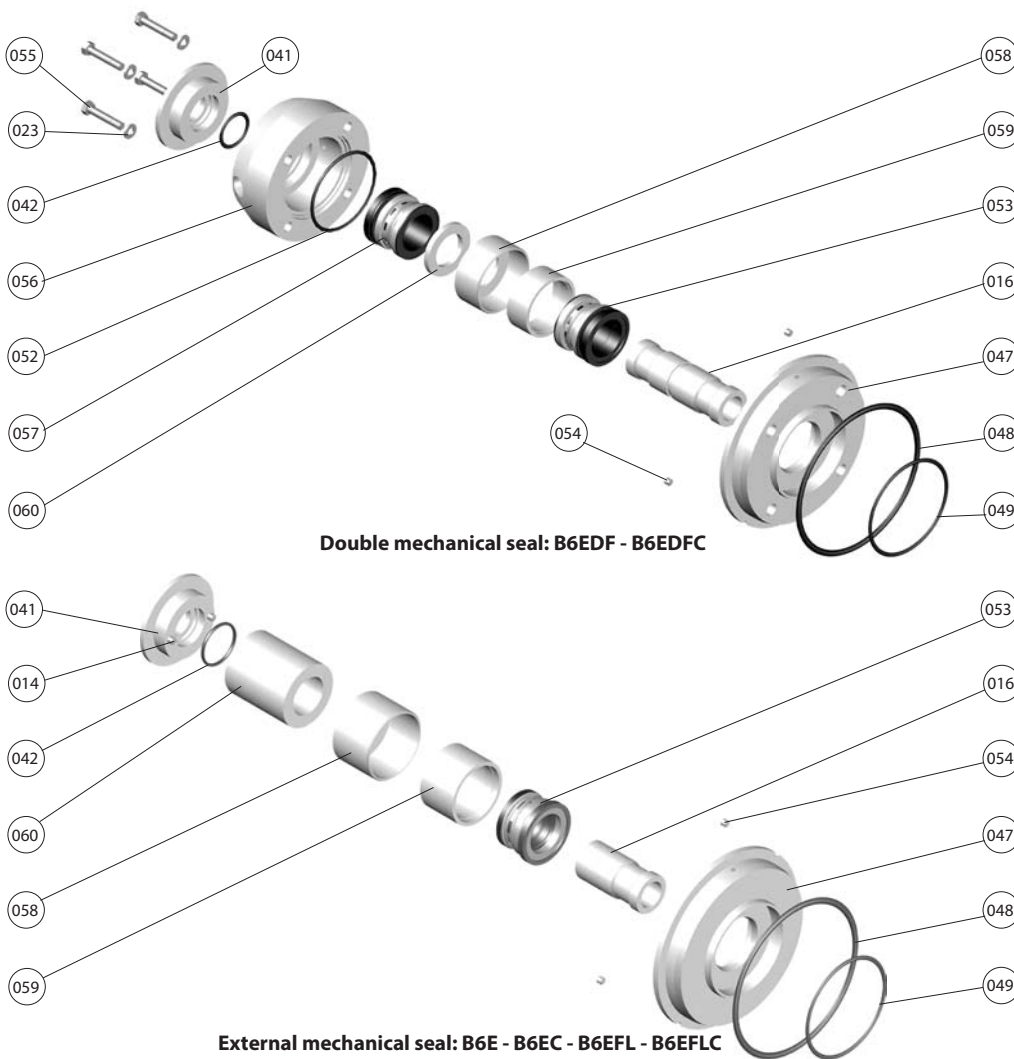

Positioning of the mechanical seal

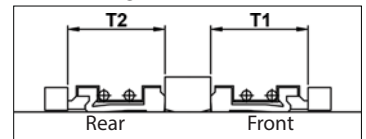

**Double mechanical seal:
B6EDF - B6EDFC**

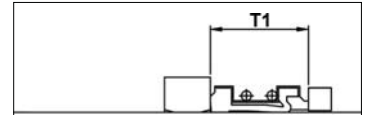

**External mechanical seal:
B6E - B6EC - B6EFL - B6EFLC**



Seal's diameter	T1 (mm)
30 - 35	26
40 - 45 - 55	30
65	33
75	40

Seal's diameter	T2 (mm)
30 - 35	26
40 - 45 - 55	30
65	33
75	40

NOMENCLATURE OF MECHANICAL SEAL PARTS

POS.	DESCRIPTION	QUANTITY	MATERIAL
014	Cylindrical pin	2	SS 304
016	Shaft sleeve	1	PP - PVDF - PE-UHMW - PVC
023	Washer - seal chamber	4	SS 316
041	Spray guard	1	PP
042	O-ring - spray guard	1	EPDM - FPM - PFA - FFKM
047	Seal chamber	1	PP - PVDF - PEHD - PVC
048	O-ring - seal chamber	1	EPDM - FPM - FFKM
049	O-ring - seal chamber	1	EPDM - FPM - FFKM
052	O-ring - external chamber	1	EPDM - FPM - FFKM
053	Mechanical seal	1	SS 316 - SiC - SiC
054	Cylindrical pin - seal chamber	2	SS 304
055	Screw - seal chamber	4	SS 316
056	External seal chamber	1	PP
057	Mechanical seal	1	SS 316 - SiC - SiC
058	External reinforcement	1	PP
059	Internal reinforcement	1	PP
060	Spacer	1	PP

B6EDF - B6EDFC MECHANICAL SEAL TECHNICAL DATA

Seal diameter (mm)	Temperature range (°C)	Max. pressure (Bar g)	Max. RPM
30 - 35 - 40	-40 / +40	6,5	3500
	-40 / +60	5	
45 - 55	-40 / +60	4	1780
65 - 75	-40 / +35	3	
		-40 / +60	2

APPLICABLE API PLANS: 01 - 11 - 12 - 32 + 52 - 53 - 54

B6E - B6EC - B6EFL - B6EFLC MECHANICAL SEAL TECHNICAL DATA

Seal diameter (mm)	Temperature range (°C)	Max. pressure (Bar g)	Max. RPM
30 - 35 - 40	-40 / +40	6,5	3500
	-40 / +60	5	
45 - 55	-40 / +60	4	1780
65 - 75	-40 / +35	3	
		-40 / +60	2

APPLICABLE API PLANS: 01 - 11 - 12 - 32

7.7 B6IDF-B6IDFC-B6IDFH-B6I-B6IC-B6IFL-B6IH-B6IFLH-B6IFLC SEALS

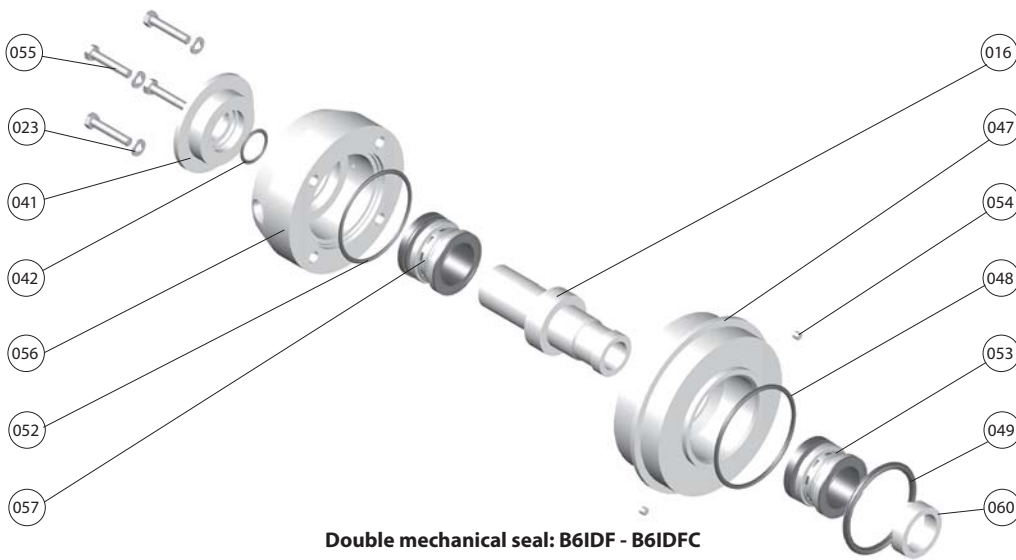

Double mechanical seal: B6IDF - B6IDFC

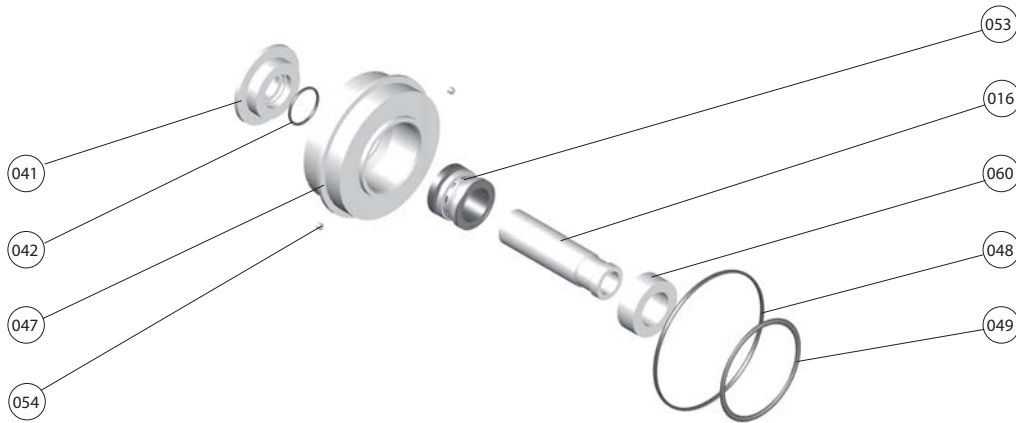

Internal mechanical seal: B6I - B6IC - B6IFL - B6IFLC

Positioning of the mechanical seal

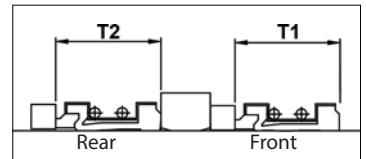

**Double mechanical seal:
B6IDF - B6IDFC**

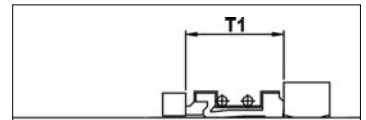
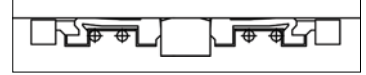

**External mechanical seal:
B6I - B6IC - B6IFL - B6IFLC**



Seal's diameter	T1 (mm)
30 - 35	26
40 - 45 - 55	30
65	33
75	40

Seal's diameter	T2 (mm)
30 - 35	26
40 - 45 - 55	30
65	33
75	40

NOMENCLATURE OF MECHANICAL SEAL PARTS

POS.	DESCRIPTION	QUANTITY	MATERIAL
016	Shaft sleeve	1	PP - PVDF - PE-UHMW - PVC
023	Washer - seal chamber	4	SS 304
041	Spray guard	1	PP
042	O-ring - spray guard	1	EPDM - FPM - FEP - FFKM
047	Seal chamber	1	PP - PVDF - PEHD - PVC
048	O-ring - seal chamber	1	EPDM - FPM - FFKM
049	O-ring - seal chamber	1	EPDM - FPM - FFKM
052	O-ring - external chamber	1	EPDM - FPM - FFKM
053	Mechanical seal	1	SS 316 - SiC - SiC
054	Cylindrical pin - seal chamber	2	SS 304
055	Screw - seal chamber	4	SS 304
056	External seal chamber	1	PP
057	Mechanical seal	1	SS 316 - SiC - SiC
060	Spacer	1	PP - PVDF - PEHD - PVC

B6IDF - B6IDFC MECHANICAL SEAL TECHNICAL DATA

Seal diameter (mm)	Temperature range (°C)	Max. pressure (Bar g)	Max. RPM
30 - 35 - 40	-40 / +60	10	3500
45 - 55		8,5	
65 - 75			1780
APPLICABLE API PLANS: 01 - 11 - 12 - 32 + 52 - 53 - 54			

B6I - B6IC - B6IFL - B6IFLC MECHANICAL SEAL TECHNICAL DATA

Seal diameter (mm)	Temperature range (°C)	Max. pressure (Bar g)	Max. RPM
30 - 35 - 40	-40 / +60	10	3500
45 - 55		8,5	
65 - 75			1780
APPLICABLE API PLANS: 01 - 11 - 12 - 32			

8.0 AUXILIARY COMPONENTS

8.1 SYMBOLS LEGEND AND NOTES

INLET Inlet (auxiliary flushing)

OUTLET Outlet (auxiliary flushing)

 Manual control valve for pressure and flow rate adjustment

 Check valve

 Pressure and flow rate adjustment orifice

 Y filter

 Pressure indicator

 Temperature indicator

 Flow rate indicator

 Level indicator

 Pressure switch

 Level sensor

NOTE: A double seal API PLAN is always combined with a single seal API PLAN. Example 01+ 52 or 12+53 or 32+54.

 The auxiliary flushing liquid should always be compatible with the pumped liquid and the construction materials of the wetted parts.

8.2 FLUSHING SYSTEM FOR SINGLE SEAL: API PLAN 10

DESCRIPTION: internal flushing system supplied as standard that allows liquid pumped from the pump casing to the seal to pass through an internal orifice.

USE: standard operating conditions, excluding the presence of solids and crystals and high temperatures.

BENEFITS: improves seal lubrication. Reduces the likelihood of the liquid freezing and reduces the temperature inside the gland. Does not entail prior calculation or additional cost.

DISADVANTAGES: cannot be used with dirty or excessively hot liquids. The quantity of liquid must always be checked to ensure that it is enough to cool the gland.

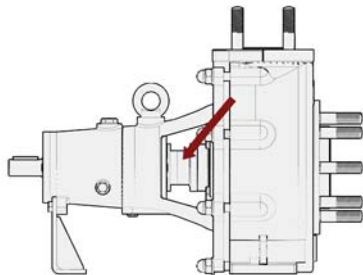

8.3 FLUSHING SYSTEM FOR SINGLE SEAL: API PLAN 11

DESCRIPTION: flushing system that recirculates liquid pumped from the discharge to the seal through an orifice for flow rate adjustment.

USE: standard operating conditions, excluding the presence of solids and crystals and hot liquids.

BENEFITS: the liquid is injected at a higher pressure than that foreseen for Plan 01 (equal to the operating pressure) improving flushing efficiency.

DISADVANTAGES: cannot be used with dirty or excessively hot liquids. The quantity of recirculating liquid must always be checked to ensure that it is enough to cool the gland. The recirculation flow rate and dimension of the orifice must be calculated.

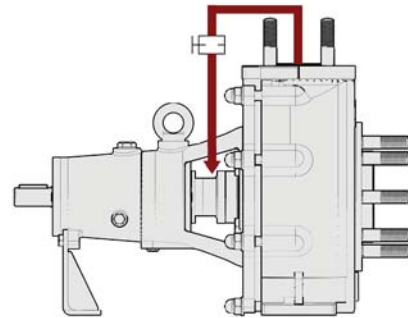

NOTE: The orifice must not be smaller than 1/8".

QUANTITY OF FLUSHING LIQUID

Seal Ø (mm)	950 - 1780 RPM	2950 - 3500 RPM	Pressure
30 - 35 - 40	1 litres / min	1.5 litres / min	Operating pressure
45 - 55	1.5 litres / min	2.5 litres / min	
65 - 75	2 litres / min	-	

8.4 FLUSHING SYSTEM FOR SINGLE SEAL: API PLAN 12

DESCRIPTION: flushing system that recirculates liquid pumped from the discharge to the seal through an orifice and a filter.

USE: standard operating conditions, excluding use with hot liquids. Recommended for low concentrations of solids or crystals.

BENEFITS: the liquid is injected at a higher pressure than that foreseen for Plan 01 improving flushing efficiency. The filter reduces the presence of solids.

DISADVANTAGES: cannot be used with excessively dirty or hot liquids. The quantity of recirculating liquid must always be checked to ensure that it is enough to cool the gland. The recirculation flow rate and dimensions of the orifice and filter must be calculated.

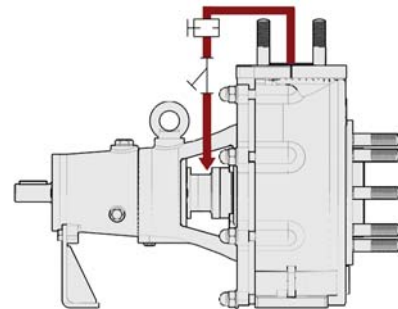

NOTE: The strainer must be cleaned periodically.

NOTE: The orifice must not be smaller than 1/8".

 Fluid leakages may occur during routine cleaning and/or replacement of the filter. These operations must be carried out when the pump is not in operation and using appropriate safety equipment.

QUANTITY OF FLUSHING LIQUID

Seal Ø (mm)	950 - 1780 RPM	2950 - 3500 RPM	Pressure
30 - 35 - 40	1 litres / min	1.5 litres / min	Operating pressure
45 - 55	1.5 litres / min	2.5 litres / min	
65 - 75	2 litres / min	-	

8.5 FLUSHING SYSTEM FOR SINGLE SEAL: API PLAN 32

DESCRIPTION: flushing system providing clean liquid from an external source with a temperature ranging from +10°C to +20°C.

USE: recommended for liquids containing high concentrations of solids or crystals and for high temperatures.

BENEFITS: the use of a flushing system with liquid from an external source extends the life of the mechanical seal, preventing it from leaking or breaking.

DISADVANTAGES: the auxiliary flushing liquid is fully dispersed in the liquid pumped (compatibility of the two liquids must be checked before use).

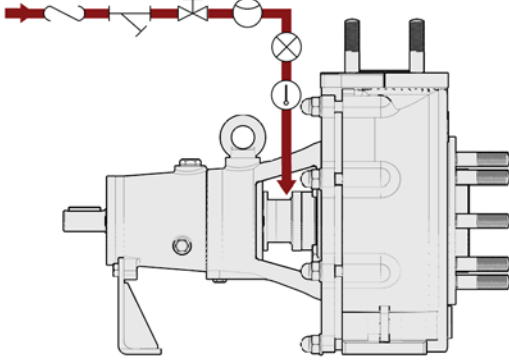

NOTE: Flushing of the auxiliary liquid must be continuous, even during start-up and stopping.

QUANTITY OF FLUSHING LIQUID

Seal Ø (mm)	950 - 1780 RPM	2950 - 3500 RPM	Pressure
30 - 35 - 40	1 litres / min	1.5 litres / min	1 Bar higher than the operating pressure
45 - 55	1.5 litres / min	2.5 litres / min	
65 - 75	2 litres / min	-	

8.6 FLUSHING SYSTEM FOR DOUBLE SEAL: API PLAN 52

DESCRIPTION: a non-pressurised, external liquid tank sends clean, cold liquid (+10° / +20°C) to the seal using forced circulation provided by a thermosiphon effect or pumping system.

USE: recommended for pumped liquids containing high concentrations of solids or crystals and for high temperatures.

BENEFITS: recirculation of liquid through the tank prevents wastage of flushing liquid. PLAN 52 avoids dispersion of the auxiliary liquid into the pumped liquid.

DISADVANTAGES: the flushing circuit is complex.

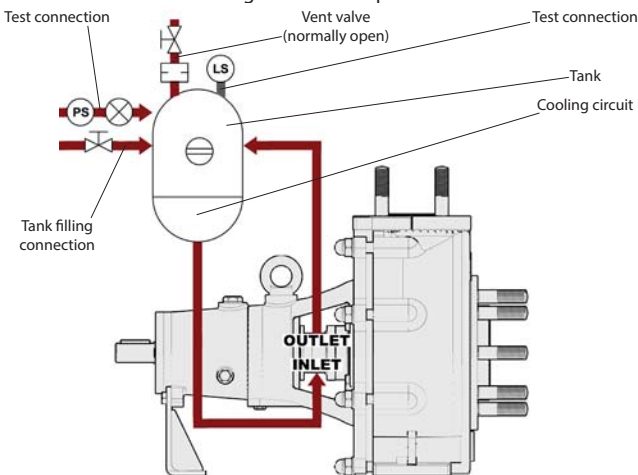

Some installation instructions are given here below:

- The tank must be as close as possible to the pump. A distance of 30 to 45 cm from the shaft axis is recommended. Installation of the tank at a distance of more than a metre is not recommended.
- The capacity of the tank must be consistent with the size of the pump. The minimum capacity should be at least 4 litres for every 25 mm of diameter of the pump shaft. Maintaining a minimum quantity of 8 litres.

- Provide a liquid cooling circuit.
- Install a closure valve on both the OUTLET and INLET piping to the seal so that the tank can be isolated if the pipework needs replacing.
- Pipework should be installed perpendicular to the gland (vertically). If horizontal installation is the only option, make sure that the flushing pipe running to the gland has a gradient of 1° to 5° to prevent air pockets.
- INLET piping running to the seal must have a minimum diameter of 3/4", whilst the OUTLET piping must have a minimum diameter of 1/2".
- Avoid elbows or tight bends along the short stretch of piping.
- Liquid contained within the tank must be topped up at a height of more than 25 mm above the maximum level of liquid contained therein.
- Fit an alarm system that activates a solenoid valve in the event of insufficient pressure inside the inlet piping.
- Provide a drainage hole for emptying the tank.

NOTE: Flushing of the auxiliary liquid must be continuous, even during start-up and stopping.

 Vent the tank using a vent valve before start-up.

QUANTITY OF FLUSHING LIQUID

Seal Ø (mm)	950 - 1780 RPM	2950 - 3500 RPM	Pressure
30 - 35 - 40	1 litres / min	1.5 litres / min	1 Bar higher than the operating pressure
45 - 55	1.5 litres / min	2.5 litres / min	
65 - 75	2 litres / min	-	

8.7 FLUSHING SYSTEM FOR DOUBLE SEAL: API PLAN 53

DESCRIPTION: a pressurised, external liquid tank sends clean, cold liquid (+10° / +20°C) to the seal using forced circulation provided by a thermosiphon effect or pumping system.

USE: recommended for pumped liquids containing high concentrations of solids or crystals and for high temperatures.

BENEFITS: prevents the auxiliary liquid from becoming exposed to atmospheric pressure and guarantees zero emissions to the environment. A pressurised flushing system improves cleaning through the formation of a film between the surfaces of the seal rings.

DISADVANTAGES: the flushing circuit is complex and requires constant pressurisation. The auxiliary flushing liquid could become dispersed in the liquid pumped (compatibility of the two liquids must be checked). The pressurisation gas could dissolve in the auxiliary liquid. If the liquid pumped was dirty it could cause the flushing liquid to deteriorate, in which case it would have to be replaced regularly.

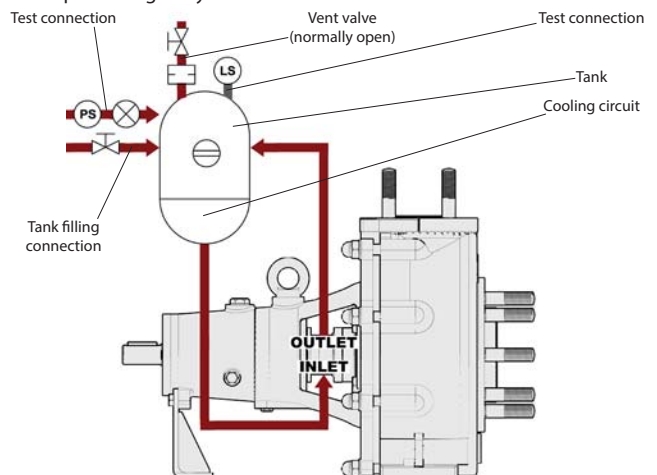

Some installation instructions are given here below:

- The tank must be as close as possible to the pump. A distance of 30 to 45 cm from the shaft axis is recommended. Installation of the tank at a distance of more than a metre is not recommended.
- The capacity of the tank must be consistent with the size of the pump. The minimum capacity should be at least 4 litres for every 25 mm of diameter of the pump shaft. Maintaining a minimum quantity of 8 litres.

- Provide a liquid cooling circuit.
- Install a closure valve on both the OUTLET and INLET piping running to the gland so that the tank can be isolated if the pipework needs replacing.
- Pipework should be installed perpendicular to the gland (vertically). If horizontal installation is the only option, make sure that the flushing pipe running to the gland has a gradient of 1° to 5° to prevent air pockets.
- INLET piping running to the seal must have a minimum diameter of 3/4", whilst the OUTLET piping must have a minimum diameter of 1/2".
- Avoid elbows or tight bends along the short stretch of piping.
- Liquid contained within the tank must be topped up at a height of more than 25 mm above the maximum level of liquid contained therein.
- Fit an alarm system that activates a solenoid valve in the event of insufficient pressure inside the inlet piping.
- Provide a drainage hole for emptying the tank.

NOTE: Flushing of the auxiliary liquid must be continuous, even during start-up and stopping.

 Vent the tank using a vent valve before start-up.

QUANTITY OF FLUSHING LIQUID

Seal Ø (mm)	950 - 1780 RPM	2950 - 3500 RPM	Pressure
30 - 35 - 40	1 litres / min	1.5 litres / min	1 Bar higher than the operating pressure
45 - 55	1.5 litres / min	2.5 litres / min	
65 - 75	2 litres / min	-	

8.8 FLUSHING SYSTEM FOR DOUBLE SEAL: API PLAN 54

DESCRIPTION: pressurised, external flushing system. Clean, cold liquid (+10° / +20°C) is circulated by an external pump or pressure system.

USE: recommended for pumped liquids containing high concentrations of solids or crystals, high temperatures or high operating pressures.

BENEFITS: provides increased flow rate and greater heat dissipation. There is no tank to size and manage and the flushing circuit is simple.

DISADVANTAGES: the flushing liquid could become dispersed in the liquid pumped (compatibility of the two liquids must be checked). If the liquid pumped was dirty it could cause the flushing liquid to deteriorate, in which case it would have to be replaced regularly. Liquid consumption could be high and costly.

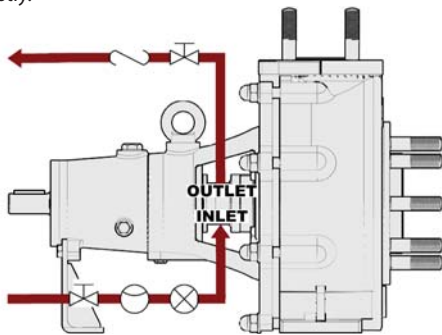

NOTE: Flushing of the auxiliary liquid must be continuous, even during start-up and stopping.

QUANTITY OF FLUSHING LIQUID

Seal Ø (mm)	950 - 1780 RPM	2950 - 3500 RPM	Pressure
30 - 35 - 40	1 litres / min	1.5 litres / min	1 Bar higher than the operating pressure
45 - 55	1.5 litres / min	2.5 litres / min	
65 - 75	2 litres / min	-	

8.9 CONSTANT LEVEL OILERS

The oiler, supplied on request, maintains a constant level of oil in the bearings housing. It is fitted directly to the bearings housing and does not require any level adjustment.

The oiler installation procedure is as follows:

1. Unscrew the ampoule from the body of the oiler.
2. Screw the body of the oiler to the bearings housing taking care not to damage the parts during this stage. The threaded hole must be facing upwards.
3. Check that the centreline of the oiler body coincides with the constant level to be maintained in the bearings housing.
4. Fill the bearings housing with oil, through the oiler body, up to the desired level.
5. Fill the oil ampoule with oil using a funnel.
6. Insert the ampoule into the oiler body.
7. Start the pump and check that a sufficient level of oil is maintained in the bearings housing.

9.0 OUTER DIMENSIONS

9.1 DIMENSIONS OF BARE SHAFT PUMP

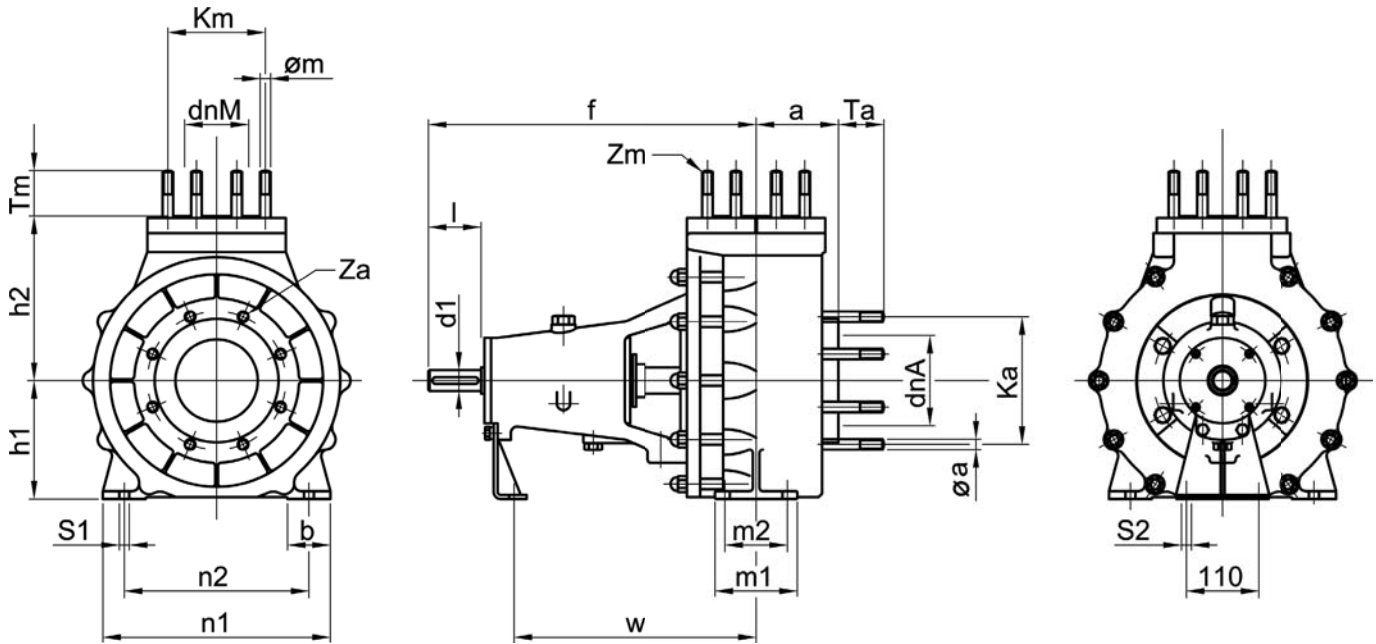

Pump model	a	f	h1	h2	b	m1	m2	n1	n2	S1	S2	w	d1	l	dnA	Ka	Øa	Za	Ta	dnM	Km	Øm	Zm	Tm						
32-160	80	385	132	160	50	100	70	240	190	14	14	285	24	50	50	125	16	4	60	32	100	12	4	60						
32-200			160	180																					265	212	65	145	40	110
40-160			132	160																					265	212	65	145	40	110
40-200	100	500	160	180	65	125	95	320	250	14	14	370	32	80	65	145	16	60	40	110	12	4	60							
40-250			180	225																				200	50	70	265	212		
50-160	100	385	160	180	65	125	95	320	250	14	14	285	24	50	80	160	16	60	50	125	12	4	60							
50-200			180	225																				200	50	70	265	212		
50-250	125	500	180	225	65	125	95	320	250	14	14	370	32	80	100	180	16	60	50	125	12	4	60							
50-315			225	280																				345	280					
65-160	100	500	160	200	65	125	95	280	212	14	14	370	42	110	125	210	16	60	65	145	16	4	60							
65-200			180	225																				320	250					
65-250	125	530	200	250	65	125	95	360	280	18	14	370	42	110	125	210	16	60	80	160	12	4	60							
80-200			180	180																				400	315					
80-250	125	530	225	280	65	125	95	400	315	14	14	370	42	110	125	210	16	60	80	160	12	4	60							
80-315			250	315																				435	355					
80-400	140	530	280	355	65	125	95	435	355	18	14	370	42	110	125	210	16	60	100	180	12	4	60							
100-200			200	280																				360	280					
100-250	140	530	225	280	65	125	95	400	315	18	14	370	42	110	150	240	20	65	125	210	12	4	60							
100-315			250	315																				400	315					
125-250	140	530	250	315	65	125	95	400	315	18	14	370	42	110	150	240	20	65	125	210	12	4	60							
125-315			355	400																				500	400					
150-250	160	670	280	375	65	125	95	500	400	22	18	500	48	110	200	295	20	65	150	240	12	4	60							
150-315			400	450																				550	450					
150-400	180	670	450	450	65	125	95	550	450	23	18	500	48	124	250	362	22	65	100	200	298	12	4	60						
200-315			355	450																					550	450				
200-400	180	670	410	450	65	125	95	550	450	23	18	500	48	124	250	362	22	65	100	200	298	12	4	60						
200-400			410	450																					550	450				

9.2 DIMENSIONS OF PUMP UNIT

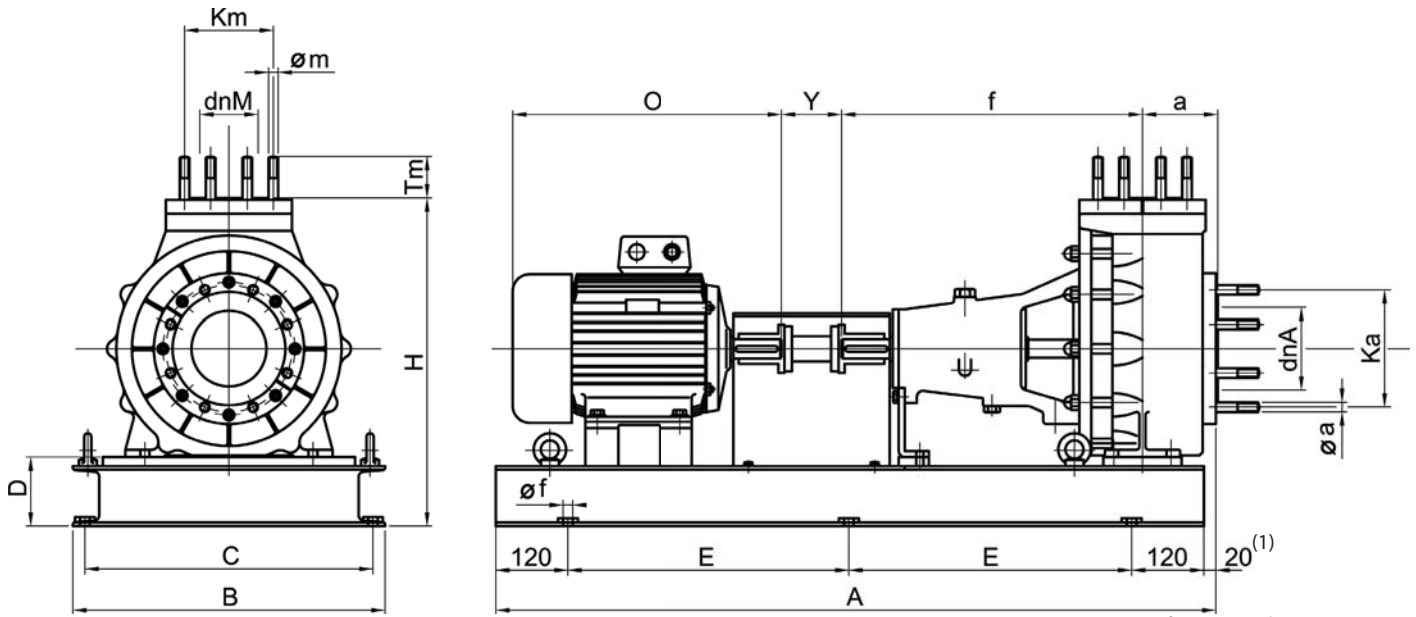

NOTE 1: 30 mm for CGD and CGD-E 100-250

Pump model	Motor frame	A	B	C	D	E	H	Y	O	Øf	a	f	dnA	Ka	Øa	dnM	Km	Øm	Ta	Tm				
32-160	80-90	958	410	377	80	-	372	100	16	100	80	385	50	125	32	100	16	60	60	-				
	100-112-132	1103																						
	160	1265																						
32-200	80-90	958																			392			
	100-112-132	1080																			420			
	160	1190																			420			
40-160	80-90	958																			372			
	100-112-132	1103																			372			
	160	1265																			372			
40-200	80-90	945																			420			
	100-112-132	990																			420			
	160	1285																			512.5			
40-250	90-100-112	1180	520	487	95	600	500																	
	132-160-180	1460			115	620																		
	200	1500			115	620																		
50-160	80-90	978	410	377	80	-	420	100	16	100	385	80	160	50	125	16	60	60	-					
	100-112	1065																						
	132-160	1285																		512.5				
50-200	90-100-112	1045																		-	440			
	132-160	1285																		512.5	440			
	180	1345																		500	467	100	542.5	
50-250	90-100-112	1205																		520	487	95	-	500
	132-160	1425																				115	582.5	520
	180-200	1565																				140	652.5	545
50-315	100-112	1205																		570	520	95	-	600
	132-160	1425																			537	115	582.5	600
	180-200	1565																			115	652.5	620	
65-160	80-90	1133	410	377	80	-	440	100	100	100	180	65	145	-	-	-	-	-	-					
	100-112	1220																						
	160	1400																						

VALUE SUPPLIED BY THE MANUFACTURER OF THE MOTOR (depends on the brand of motor)

Pump model	Motor frame	A	B	C	D	E	H	Y	O	Øf	a	f	dnA	Ka	Øa	dnM	Km	Ta	Tm	Øm
65-200	90-100-112	1220	520	487	95	480	500	140	VALUE SUPPLIED BY THE MANUFACTURER OF THE MOTOR (depends on the brand of motor)	16	100	500	100	180	16	80	160	60	60	16
	132-160	1440				590														
	180-225	1500				620														
65-250	100-112-132	1303	600	567	115	521.5	545													
	132-160-180	1610				675	580													
	225	1720				130	730													
80-200	100-112-132	1303	520	484	95	521.5	525													
	160-180	1505				622.5	550													
	200-225	1720				487	120				730	550								
80-250	112-132-160	1450	570	537	95	605	600													
	180-200	1610				652.5	640													
	225-250-280	1895				630	597				185	757.5	690							
80-315	132-160	1495	650	617	115	617.5	680													
	180-200	1680				710														
	225-250	1770				755														
80-400	160-180	1555	700	667	115	647.5	750													
	200	1685				712.5					750									
	225	1770				755														
100-200	100-112-132	1303	580	525	95	521.5	575													
	160-180	1525				632.5														
	200-225	1655				697.5														
100-250	132-160-180	1610	630	597	115	675	620													
	280	1775				630	590	185	757.5	690										
	315	2100				760	617	215	915	720										
100-315	180	1610	650	617	115	675	680													
	200	1610				730														
	220-250	1720				730														
125-250	132-160	1510	640	585	115	625	720													
	180-200	1610				675														
	225-250	1720				730														
125-315	160-180	1430	700	667	135	585	750													
	200-225	1770				755														
	250-280-315	1915				827.5														
150-250	132-160	1570	640	585	115	655	770													
	180-200	1670				705														
	225-250-280	1850				795														
150-315	160-180-200	1810	800	750	150	775	867													
	225-250	1920				830														
	280-315	2120				930														
150-400	180-200	1810	900	800	155	775	900													
	225-250	1920				830														
	315	2120				927.5														
200-315	160-180-200	1840	900	800	155	790	995													
	225-250	1950				845														
	280-315	2350				1045														
200-400	180-200	1860	900	800	155	800	1010													
	225-250	1970				855														
	280-315	2165				952.5														



COSTUMER FOCUSED



CARE IN RESEARCH & DESIGN



CUTTING-EDGE TECHNOLOGY



SPECIAL RAW MATERIALS



APPLICATION FIELD



FUNCTIONAL TESTING



SHIPPING SOLUTIONS



AFFETTI PUMPS

YOUR SOLUTIONS

C O R R O S I V E A P P L I C A T I O N S

AFFETTI PUMPS s.r.l.
Via P. Maroncelli, 4
21053 CASTELLANZA (VA)

tel. (+39) 331-503358 (+39) 331-505595
fax. (+39) 331-483007
Sales Department: eaquila@affetti.com
Technical Department: mcassaniti@affetti.com
Web-site: www.affetti.com

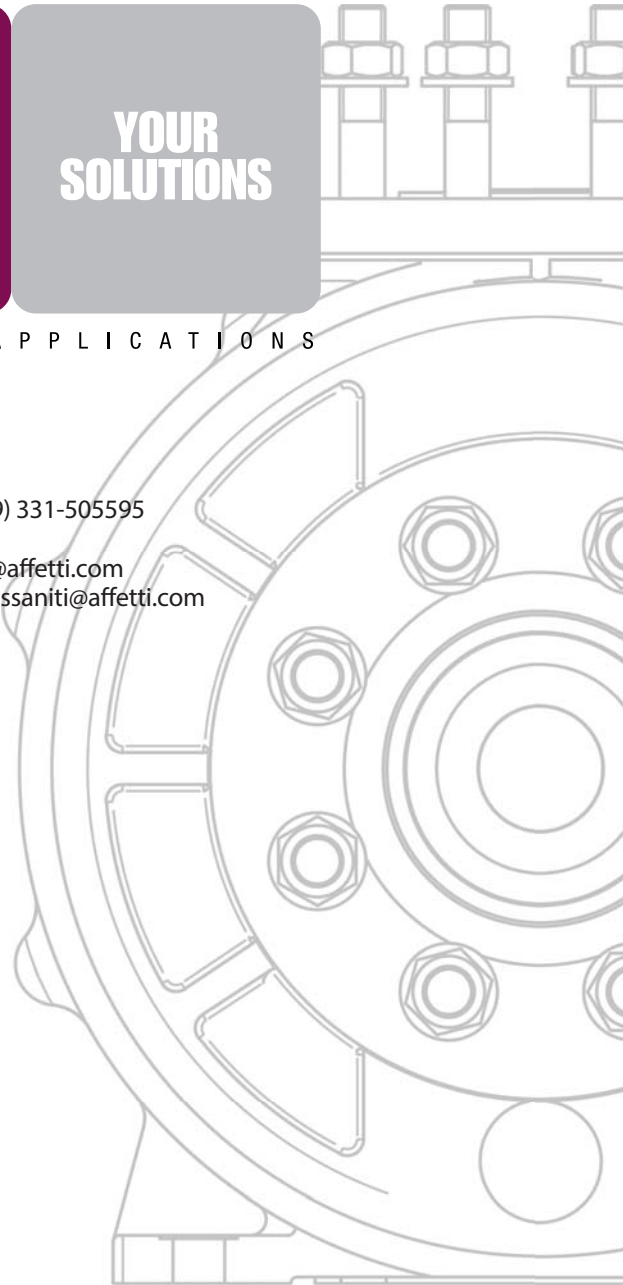

Authorized distributor

All rights reserved. Reproduction, copying or transmittal of this manual and its contents are strictly prohibited without prior authorisation from the manufacturer.